

STEAMOVAP

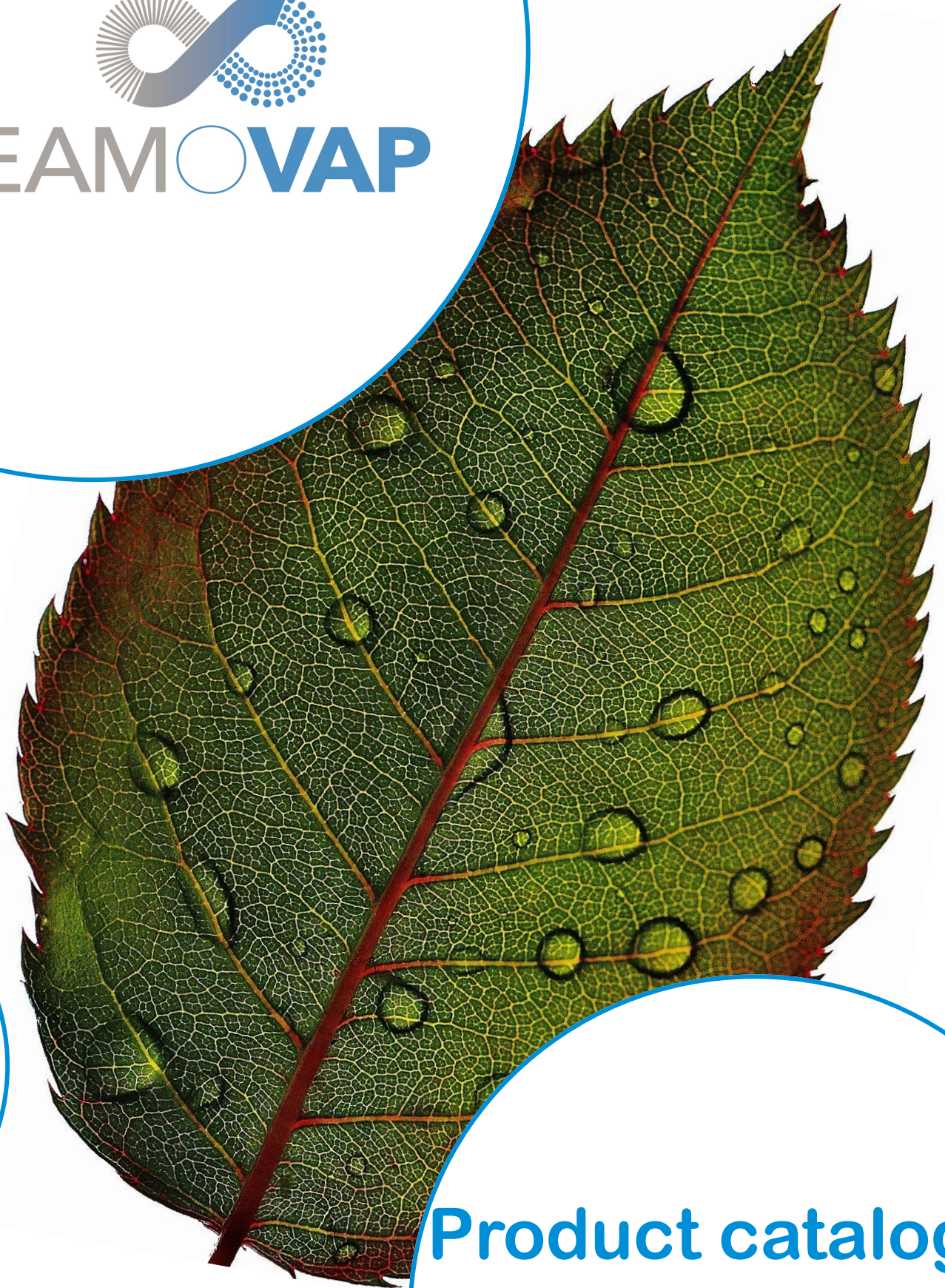

# Product catalog

Edition 2025



# TABLE OF CONTENTS

## ABOUT STEAMOVAP®



**MISSION & VALUES** 4



**STEAMOCALC** 6

## ISOTHERMAL HUMIDIFICATION



**IER** 8  
ELECTRIC RESISTIVE STEAM HUMIDIFIER



**RES** 12  
STEAMÖRES RESIDENTIAL



**ISE** 14  
STEAM EXCHANGE HUMIDIFIER

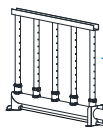

**STEAM DISTRIBUTION** 18  
SR, SO OR SB MODELS



**LIVE STEAM** 24  
SELECTION GUIDE

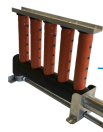

**ILS** 25  
LIVE STEAM HUMIDIFIER

## ADIABATIC HUMIDIFICATION



**AUL** 32  
ULTRASONIC HUMIDIFIER



**ACA** 34  
ATOMIZING HUMIDIFIER



**AEM** 36  
ABSORPTION HUMIDIFIER

## CONTROLS & WATER TREATMENT



**CONTROLS** 38



**WF, WS & WRO** 40  
WATER FILTERS & CONDITIONNER

## RESOURCES



**RH% & HUMAN HEALTH** 42



**USEFUL FORMULAS** 45

# BUILDING TRUST ONE PROJECT AT A TIME

## OUR MISSION

Our mission is to help our clients to achieve required **humidity** level for best indoor air quality using **sustainable solutions**.

## OUR VALUES



### Customer satisfaction

We succeed through satisfied customers, we are proactive and easy to work with.



### Team work

We foster a culture that promotes excellence, teamwork, inclusion, leadership and growth for our employees and business partners.



### Innovation

We believe there is always a better way, we encourage change and innovation and seek the opportunities its offers.



### Integrity

We act with honesty, fairness, respect and safety, furthering a culture of unquestioned integrity.



### Expertise & practical solutions

We offer knowledge and practical solutions, we deliver on our promises.



### Sustainability

We behave responsibly as a corporate citizen. Through our products, services, operations and community involvement, we promote the efficient use of resources to benefit all people and our planet.



### Excellence

We deliver quality and excellence

## OUR TEAM

**steamOvap®** has been founded in 2016 by Eric Landry Msc science and Bernard Saint-yves. Eric holds a master's degree in mechanical engineering, the subject of which is the definition of an algorithm to predict the non-wetting distance during the injection of saturated steam into an air stream; which makes him one of the few experts in steam humidification in the world. Bernard is bringing a broad and long professional experience both from North America and Europe, he has worked in large multinational or very small organizations. He is an expert in Quality and Productivity.

Our success is the result of the work of our extraordinary team, made up of our employees who help us design and manufacture our products and provide our customers with exceptional service.



This fantastic team is supported by our suppliers and our network of distributors who represent our start-up company which is quickly making its mark in the HVAC world.

## DESIGNED FOR LIFE

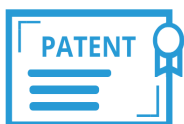

Since its inception the company has heavily invested in research and development in order to offer our model IER an electric steam humidifier. This was the opportunity to file a first patent for the unique and innovative concepts that ensure that our IER humidifier has been quickly adopted as a new benchmark.

A second patent application is pending, covering the unique and innovative design of our steam exchange humidifier—model ISE. Today **steamOvap®** humidifiers are recognized and specified by more and more engineering firms as a basis of design, or chosen by renowned contractors or customers to provide constant and precise humidity for the most demanding applications.

# RECENTS PROJECTS



**Euclid Hospital**  
*Operating rooms*  
 Product: ILS-SE Live steam  
**Cleveland, OH, USA**



**The James at Scrivener Square**  
*Condo appartements*  
 Product: RES electric steam  
**Toronto, ON, Canada**



**Eau Claire University**  
*Music laboratory*  
 Product: IER electric steam  
**Eau Claire, WI, USA**



**Pixar Animation studios**  
*Archive rooms*  
 Product: AEM evaporative  
**Emeriville, CA, USA**



**Carlson Labs**  
*Pharmaceutical production*  
 Product: ACA atomizing  
**Lincolnshire, IL, USA**



**Klinik Donaustadt**  
*Operating rooms*  
 Product: ILS-P live steam  
**Vienna, Austria**

# OTHER REFERENCES



U.S. AIR FORCE

**US Air Force Bases**  
*Medical Facilities*  
 Product: IER electric steam  
**AK, VA, TX, USA**



How you want to be treated.

**St Vincent Hospital**  
*Operating rooms*  
 Product: IER electric steam  
**Vancouver, Bc, Canada**



**Northwestern Medicine**  
*CT Scan rooms*  
 Product: IER electric steam  
**Chicago, IL, USA**



**Université de Montréal**  
*Sport center*  
 Product: IER electric steam  
**Montreal, Qc, Canada**



**SISU Health Care**  
*Pharmacy*  
 Product: IER electric steam  
**Tempe, Az, USA**



**Alstom**  
*High speed train factory*  
 Product: ILS-P Live steam  
**La Rochelle, France**



MOTOROLA

**Motorola**  
*Clean rooms*  
 Product: IER electric steam  
**Confidential location, USA**



**Chicago History Museum**  
*Artifact conservation rooms*  
 Product: IER electric steam  
**Chicago, IL, USA**



**TEVA Pharmaceuticals**  
*Pharmaceutical factory*  
 Product: IER electric steam  
**Israel**



UC Irvine Health

**UC Irvine Health**  
*MRI room*  
 Product: IER electric steam  
**Yorba linda, Ca, USA**



**Hôpital Enfant Jésus - NCH**  
*Critical care unit*  
 Product: ILS-SE live steam  
**Quebec, Qc, Canada**



**General Electric**  
*Gas turbine production*  
 Product: IER electric steam  
**Batna, Algeria**



IsoCanMed Inc.

**IsoCanMed**  
*Marijuana growing rooms*  
 Product: IER electric steam  
**Louiseville, Qc, Canada**



**Milwaukee Library**  
*Conservation rooms*  
 Product: IER electric steam  
**Milwaukee, WI, USA**



University Hospitals  
 The Science of Health. The Art of Compassion.

**UH Parma Medical Ctr**  
*Hyperbaric chambers*  
 Product: IER electric steam  
**Parma, Oh, USA**



**Moderna Museum**  
*Artifact conservation rooms*  
 Product: IER electric steam  
**Stockholm, Sweden**



U.S. Department of Veterans Affairs

**US Veterans Affairs**  
*In patient rooms*  
 Product: IER electric steam  
**Several locations, USA**

FIND YOUR EDGE



**TruFusion**  
*Hot yoga studio*  
 Product: IER electric steam  
**Several locations, USA**

# STEAMOcalc

**steamOcalc** is a web application available online as part of our website. It is absolutely free to use it, no login or password are required to access it or to use it.

<https://steamovap.com/solutions/isothermal-humidifier-load-calculator/>

It allows anyone to calculate steam humidification load based on the common design parameters for heating (winter) or economizer (free cooling) modes. It is the only humidification load calculation program with Energy Recovery Ventilator (ERV) option included.

You simply have to enter in-space desired conditions, duct dimensions and air flow information, as well as outside air conditions. **steamOcalc** will calculate the required humidification load, will suggest a steam humidifier model and offer a list of options for the in-duct steam distribution.

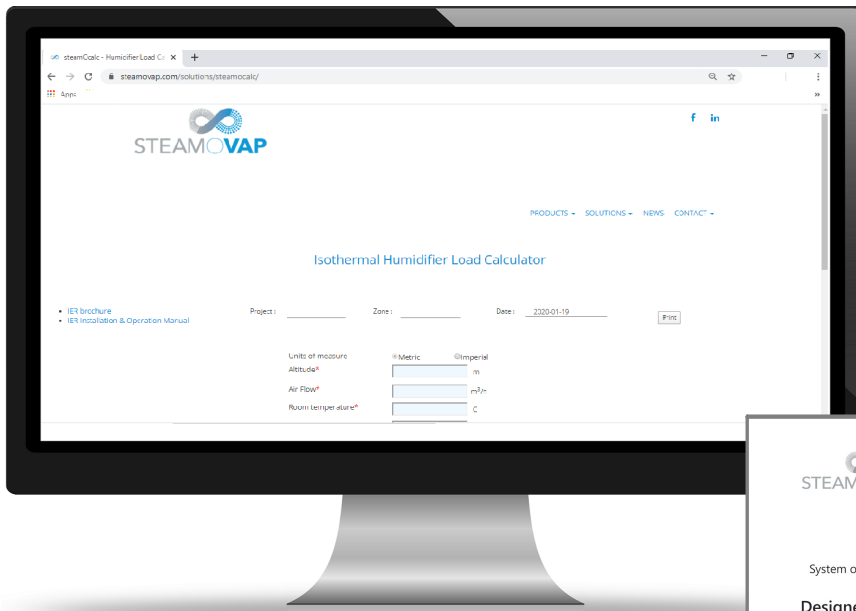

Quick access to  
steamOcalc

Non-wetting distance and pressure drop across steam ramps are estimated for all possible steam distribution options, this will help you to select the best steam distribution option for your project.

If you need to compare calculation made by **steamOcalc** with an alternative calculation method. Click on "display calculated value" box and all of the data that have been generated by the program will be indicated.

You can enter information about your project, zone and date, and if you need to keep record, press the print button to quickly transfer the results on pdf file report.

A selection report as well as generic submittal can also be generated in a few seconds by clicking on the "submittal" button.

**steamOcalc** is free access to all, you can use it as often as you need. Do not hesitate to share feedback and comments with us.

**STEAMOcalc** Project name: LAM CA32  
Zone: 1  
Date: 2025-02-02

**Humidifier selection report**

System of unit: metric Elevation: 300 (m)

Outside air conditions (2)			Space conditions (1) & distribution		
DB temp.	RH%	OA intake %	DB temp.	RH%	Distribution
0 (°C)	50	30	21 (°C)	40	In duct

Duct information				ERV (6)	
Air volume	Type	Width	Height	Air velocity	Installed
8000 (m3/h)	Square	1000 (mm)	500 (mm)	(m/s)	No

Calculated load: 12.25 (kg/h) Humidifier model: IER12

Mixed air (3)		Before humidifier (4)		After humidifier (supply) (5)	
DB temp.	RH %	DB temp.	RH %	DB temp.	RH %
14.7 (°C)	47.18	21 (°C)	31.72	21 (°C)	40

SO-H Steam header							SO-R Vertical ramps		Non-Wetting	Pressure
SO Model	Diam.	Length	Model	Qty	Diam.	Length	D. in betw	distance	drop	
SO-H50	DN50	833 (mm)	SO-R40	3	40 (mm)	363 (mm)	333 (mm)	166.3 (mm)	10.15 (pa)	

**Humidification system schematic view**



# STEAM HUMIDIFIERS ISOTHERMAL





**IER** humidifier by **steamOvap®** is an electric steam generator that uses water immersed resistive heating elements to produce pure and sterile steam that is easy to distribute in air handling unit or ventilation duct.

**IER** humidifier can be supplied with tap or treated water such as softened or reverse osmosis water. When tap water is used, the scale will come off the heating elements by the natural contraction and expansion of the tube heaters. Scale pieces then accumulate at the bottom of the cylinder without the risk of clogging the drain outlet.

Unlike electrode boiler humidifiers steam production of the **IER** humidifier is not altered by the electrodes or water conditions, it will not change over time and it is fully proportional from 1 to 100% and constant.

- Produces pure & sterile steam
- Capacities from 2.8 to 42.1kg/h and up to 168.1kg/h with super-heavy (see page 8)
- Constant and precise steam production +/-1%RH.
- Permanent stainless steel cylinder.
- Supplied with Modbus RTU (RS485)
- Suitable for tap or RO water without additional option.
- Optional BACnet remote control.
- Board computer and 7" touch screen .
- Polymeric access door.
- Guide & lock approach system (patent pending).
- Very robust heating elements with extra low watt density.

### BEST CHOICE FOR ENGINEERS

- Resistive immersed heaters technology - no plastic canister going to waste.
- Thermally insulated cylinder.
- Energy consumption displayed in real time.
- Robust - lowest watt density of the industry.

### PREFERRED BY CONTRACTORS

#### **Easiest to install**

- Smallest & lightest electric humidifier of the industry.

#### **Easiest to set-up and start-up**

- Unique 7in large touch screen.

#### **Easiest to service**

- Done in minutes & absolutely no spare parts required.

### INNOVATION

- EcoEnerSmart® patented function saving energy and water.
- Resistive immersed heaters technology - no plastic canister going to waste.
- Internal hydraulic circuit without check valve prone to block in open or closed position.
- 7in touch screen user interface

### MADE IN CANADA

Proudly designed and made in Canada by a dedicated team combining more than 40 years of experience in humidification.



#### **Best warranty of the industry!**

*If your humidifier installation has been verified and validated (with a start-up report) by one of our authorized representatives.*



## TECHNICAL DATA

Model	IER02	IER04	IER05	IER09	IER12	IER17	IER22	IER31
<b>Capacity</b>	2.8kg/h	4.5kg/h	6.8kg/h	11.3kg/h	15.9kg/h	22.7kg/h	29.5kg/h	42.1kg/h
<b>Power (kW)</b>	2.0kW	3.3kW	5.0kW	8.3kW	11.7kW	16.7kW	21.7kW	30.9kW
<b>Voltage (Vac) / Phase</b>	230/1	230/1 400/3	230/1 400/3	230/1 400/3	230/1 400/3	400/3	400/3	400/3
<b>Size</b>	small				medium			

Supplied with water supply braided hose and drain connection DN32.

## TECHNICAL DRAWINGS

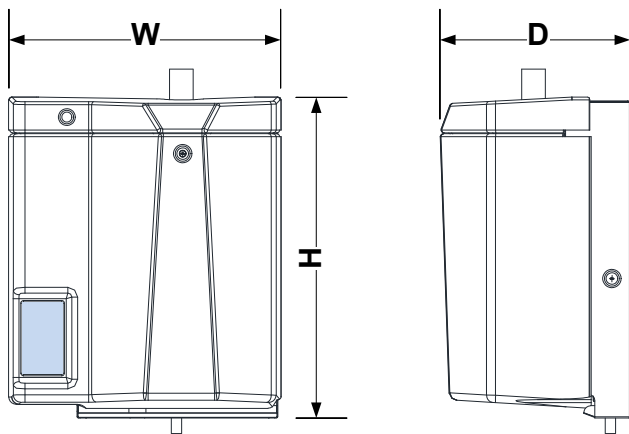

Optional Roof top enclosure

Model		IER02	IER04	IER05	IER09	IER12	IER17	IER22	IER31
<b>Dimensions]</b>	<b>W</b>	510mm				585mm			
	<b>H</b>	585mm				686mm			
	<b>D</b>	330mm				432mm			
<b>Steam outlet</b>	<b>∅</b>	[DN40]				[DN40]		[DN65]	
<b>Weight</b>	<b>Net</b>	21kg				31kg			
	<b>Oper</b>	34kg				54kg			

## NOMENCLATURE

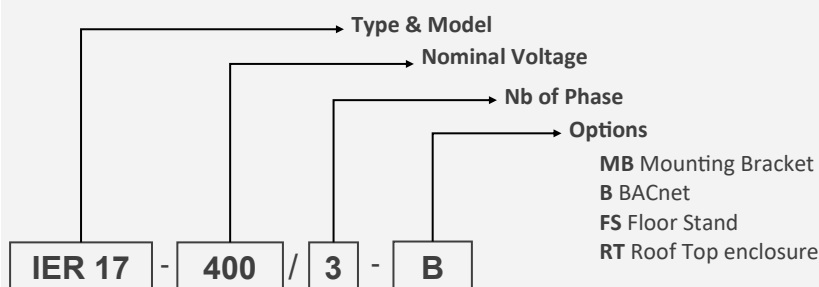

## LIST OF OPTIONS

- Wall mounting bracket
- Floor mounting rack
- Roof top weather proof enclosure (IP65)
- BACnet remote control



**IER Super Heavy** series is using same technology as the IER, it can be supplied with tap or treated water such as softened or reverse osmosis water. When tap water is used, the scale will come off the heating elements by the natural contraction and expansion of the tube heaters. Scale pieces then accumulate at the bottom of the cylinder without the risk of clogging the drain outlet.

This large capacity electric humidifier does not compromise on reliability and serviceability, thanks to the guide & lock patented design allowing for regular cleaning of the cylinder by anyone in few minutes, with no technical knowledge required, without the need for tool, special equipment, or expensive spare part or consumable such as plastic cylinder.

- Produces pure & sterile steam
- Capacities from 59 to 168.1kg/h
- Permanent stainless steel cylinder.
- Supplied with Modbus RTU (RS485)
- Suitable for tap or RO water without additional option.
- Optional BACnet remote control.
- Board computer and 7" touch screen .
- Polymeric access door.
- Guide & lock approach system (patent pending).
- Very robust heating elements with extra low watt density.
- Supplied with wall mounting bracket - optional legs for floor mount

### BEST CHOICE FOR ENGINEERS

- Resistive immersed heaters technology - no plastic canister going to waste.
- Thermally insulated cylinder.
- Energy consumption displayed in real time.
- Robust - lowest watt density of the industry.

### INNOVATION

- EcoEnerSmart® patented function saving energy and water.
- Resistive immersed heaters technology - no plastic canister going to waste.
- Internal hydraulic circuit without check valve prone to block in open or closed position.
- 7in touch screen user interface

### PREFERRED BY CONTRACTORS

#### **Easiest to install**

- Adjustable wall mounting bracket included

#### **Easiest to set-up and start-up**

- Unique 7in large touch screen.

#### **Easiest to service**

- Done in minutes & absolutely no spare parts required.

### MADE IN CANADA

Proudly designed and made in Canada by a dedicated team combining more than 40 years of experience in humidification.



#### **Best warranty of the industry!**

*If your humidifier installation has been verified and validated (with a start-up report) by one of our authorized representatives.*

## TECHNICAL DATA

Model	IER44	IER62	IER88	IER105	IER124
Capacity	59kg/h	84kg/h	118.1kg/h	143.1kg/h	168.1kg/h
Power (kW)	43.3kW	61.7kW	86.6kW	105.0kW	123.4kW
Voltage (Vac) /Phase	400/3	400/3	400/3	400/3	400/3
Size & Qty of module	1x large		2x large		

Supplied with wall mounting bracket, water supply braided hose and drain connection sleeve 1-1/4in [DN32].

## TECHNICAL DRAWINGS

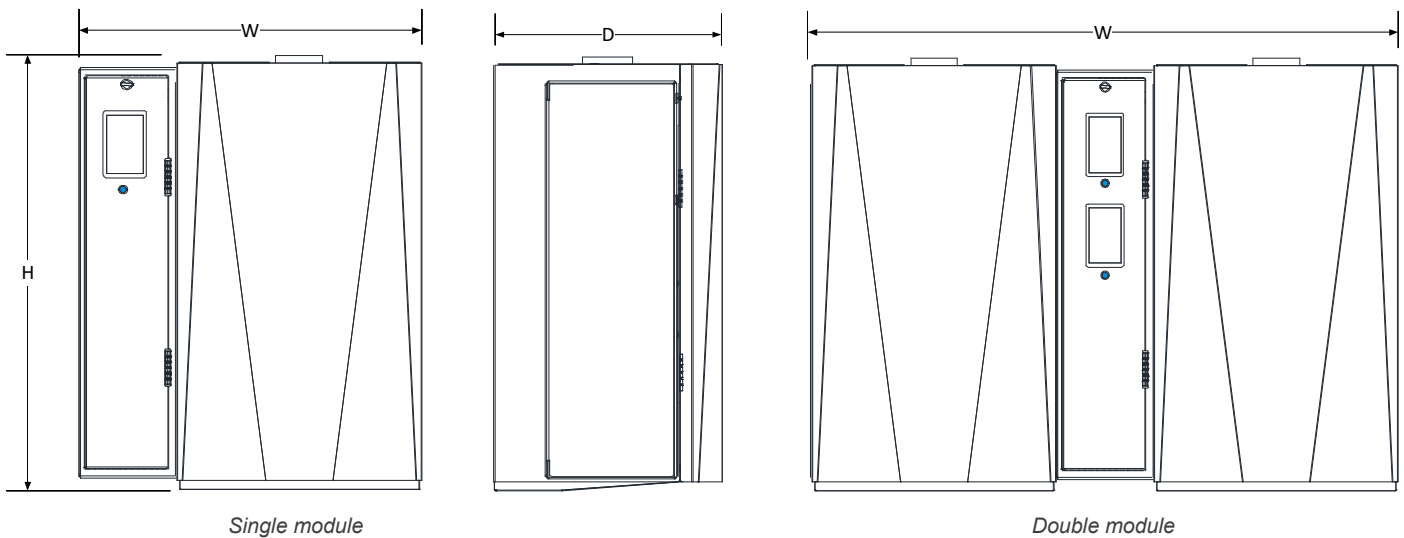

	Model	IER44	IER62	IER88	IER105	IER124
Dimensions	W	915mm		1677mm		
	H	1099mm		1099mm		
	H2	1403mm (with floor mounting rack)		1403mm (with floor mounting rack)		
	D	585mm		585mm		
Steam outlet	Qty	1x	1x	2x	2x	2x
	∅	[DN80]	[DN90]	[DN80]	[DN90]	[DN90]
Weight	Net	36kg		68kg		
	Oper	54kg		104kg		

## LIST OF OPTIONS

- Floor mounting rack
- Roof top weather proof enclosure (IP65)
- BACnet remote control



**steamOres (RES)** residential humidifier by **steamOvap®** is an electric steam generator that uses water immersed resistive heating elements to produce pure and sterile steam to humidify your home or office during winter.

**steamOres** humidifier has been designed for life. Its steam cylinder is made of stainless steel to last a lifetime. It is the only steam residential humidifier with thermal insulation offered on the market with thermal insulation of the steam cylinder and with full proportional output to save energy and improve your comfort.

Regular cleaning of the cylinder to remove scale (when you use untreated tap water) can be done by anyone in few minutes, with no technical knowledge required, without the need for tool, special equipment, or expensive spare part or consumable such as plastic cylinder.

- Produces pure & sterile steam
- Capacities from 0.8 to 5.6kg/h
- Constant and precise steam production with full proportional output by standard.
- Permanent stainless steel cylinder.
- Thermally insulated cylinder.
- Compatible with any of the smart thermostat such as Ecobee, Nest, Honeywell or other.
- Supplied with Modbus RTU (RS485)
- Suitable for tap or RO water without additional option.
- Service done in minutes without the need of special skills or spares.
- Supplied with all installation accessories.

### BEST CHOICE FOR ENGINEERS

- Resistive immersed heaters technology - no plastic canister going to waste.
- Thermally insulated cylinder.
- 0-100% full proportional output by standard
- Exceptional robustness with heater of lowest watt density of the industry.

### PREFERRED BY CONTRACTORS

#### *Easiest to install*

- Everything is in the box all accessories for a quick and easy installation are included.

#### *Easiest to set-up and start-up*

- Versatile set-up with touch pad control

#### *Easiest to service*

- Done in minutes & absolutely no spare parts required.

### INNOVATION

- Designed for life: The most sustainable residential steam humidifier offered on the market.
- Resistive immersed heaters technology: No disposable plastic canister.
- Touch pad control & embedded Modbus remote connection, allow for easy communication with other equipment such as HRV.

### MADE IN CANADA

Proudly designed and made in Canada by a dedicated team combining more than 40 years of experience in humidification.

**WARRANTY 5 YEARS** **5 year warranty on the cylinder**  
No need to replace plastic cylinder at every service!

**WARRANTY 3 YEARS** **RES humidifier is offered with a 3 year warranty.**

# TECHNICAL DATA

Model	RES230-23	RES230-29	RES230-37	RES230-42
<b>Capacity</b>	3.0kg/h	4.0kg/h	5.0kg/h	5.6kg/h
<b>Power (kW)</b>	2.3kW	2.9kW	3.7kW	4.2kW
<b>Current (A)</b>	10.0A	12.8A	16.0A	18.0A
<b>Voltage (Vac) / ph</b>	230/1			

**Kit D** (in Duct), supplied with wall mounting bracket, steam ramp, steam hose, water supply braided hose, and drain hose.

**Kit S** (in Space), supplied with space blower distribution, wall mounting bracket, steam hose (if applicable), water supply braided hose, and drain hose.

Models RES230-23 & RES230-29 are supplied with power cord and 230V standard plug.

# TECHNICAL DRAWINGS

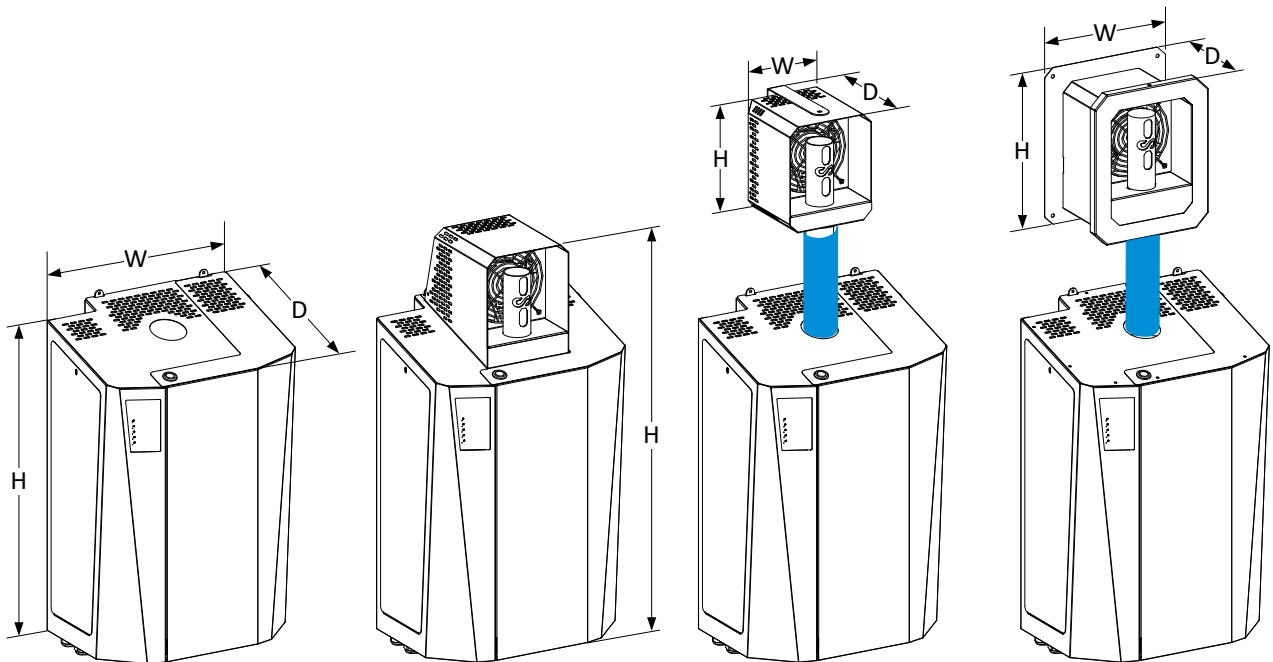

Dimensions	Kit D (in duct)			Kit S (in space) with SB-BI (Built-in)			Kit S (in space) with SB-RM (Remote)			Kit S (in space) with SB-TW (Through Wall)		
	W	H	D	W	H	D	W	H	D	W	H	D
<b>RES humidifier</b>	30cm	45cm	25cm	30cm	56.3cm	10.3cm	30cm	45cm	25cm	30cm	45cm	25cm
<b>SB blower</b>	-	-	-	-	-	-	12.5cm	16.3cm	15cm	18.8cm	22.5cm	8.8 to 16cm
<b>Weight (lb) [kg]</b>	<b>Net</b>		<b>Operating</b>		<b>Net</b>		<b>Operating</b>		<b>Net</b>		<b>Operating</b>	
<b>RES humidifier</b>	10kg		13kg		12kg		15kg		10kg		13kg	
<b>SB blower</b>	-		-		-		-		2.3kg		-	

**List of options:** Floor mounting rack, BACnet remote control.



**ISE** steam exchange humidifier by **steamOvap®** is using energy from a central boiler pressurized steam or high temperature hot water to produce pure and sterile steam that is easy to distribute in air handling unit or ventilation duct.

**ISE** humidifier can be supplied with tap or treated water such as softened or reverse osmosis water. When tap water is used, the scale will come off the heat exchanger by the natural contraction and expansion of the tube. Scale pieces then accumulate at the bottom of the cylinder without the risk of clogging the drain outlet.

Unique and patent pending design of the **ISE** is making it the most efficient, and smallest footprint of the industry, and is it the only one truly easy to service as simple by one person with no need for tools and in few minutes.

- Produces pure & sterile steam
- Full and linear modulation from 1 to 100%
- Capacities from 1.8 to 272kg/h
- Constant and precise steam production +/-1%RH.
- Permanent stainless steel cylinder.
- Supplied with Modbus RTU (RS485)
- Suitable for tap or RO water without additional option.
- Optional BACnet remote control.
- Board computer and 7" touch screen .
- Smallest foot print of the industry
- Self clean vertical heat exchanger with coil shape (patent pending).
- Thermally insulated cylinder

### BEST CHOICE FOR ENGINEERS

- Very efficient and safe design, as condensate cannot flood heat exchanger.
- Thermally insulated cylinder.
- Easy and versatile integration to steam network; left or right hand side connexion and standard wall mount.
- Self cleaning vertical heat exchanger available in stainless steel or copper + Nickel plating.

### PREFERRED BY CONTRACTORS

#### *Easiest to install*

- Smallest & lightest steam exchange humidifier of the industry.

#### *Easiest to set-up and start-up*

- Unique 7in large touch screen.

#### *Easiest to service*

- Done in minutes with no tools & absolutely no spare parts required.

### INNOVATION

- EcoEnerSmart® patented function saving energy and water.
- Unique vertical heat exchanger—patent pending.
- Internal hydraulic circuit without check valve prone to block in open or closed position.
- 7in touch screen user interface

### DESIGN & PRODUCTION

Proudly designed and made in Canada by a dedicated team combining more than 40 years of experience in humidification.



#### **Best warranty of the industry!**

*If your humidifier installation has been verified and validated (with a start-up report) by one of our authorized representatives.*

# ISE [PRESSURIZED STEAM]

ISE for pressurized steam is supplied with electric control modulating actuated valve (24Vac, signal 0-10Vdc) with fail safe, strainer and F&T condensate trap.

It is also including a wall mounting bracket, water supply braided hose and drain connection sleeve DN32.

Supply voltage is 230Vac/1ph, 50/60Hz.

It has never been so easy and simple to install a steam exchange humidifier.

Thanks to its unique & patent pending vertical heat exchanger ISE is the only steam exchange humidifier on the market that can use city (tap) water with a steam cylinder that can be opened and cleaned in minutes without the need of tool.

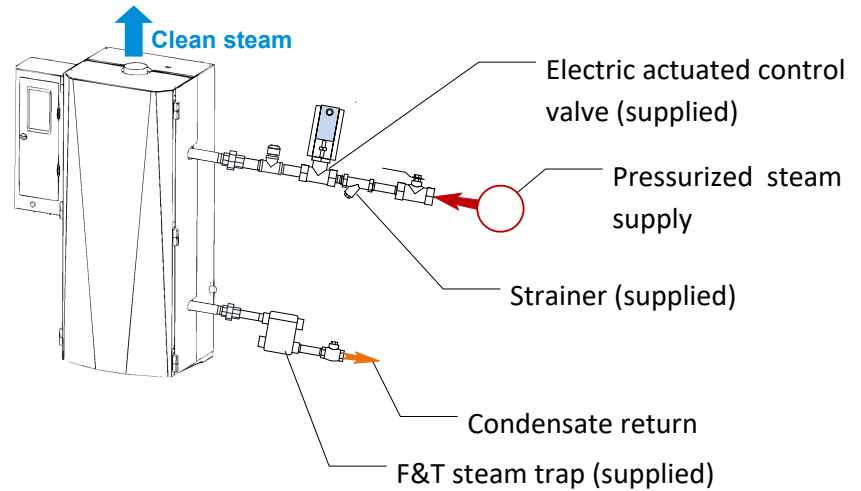

## TECHNICAL DATA [PRESSURIZED STEAM]

Model		ISE30	ISE70	ISE120	ISE170	ISE220	ISE300	ISE400	ISE600
Capacity (kg/h) <i>stainless steel heat exchanger</i>	[34kPa]	1.8	4.1	7.2	10.4	13.1	18.1	21.8	36.3
	[69Kpa]	6.8	15.9	27.2	38.6	50.0	68.1	90.9	136.3
	[103kPa]	13.6	31.8	54.5	77.2	100.0	136.3	182.0	272.7
Cylinder Qty & Size		1x small	1x medium			1x large		2x larges	

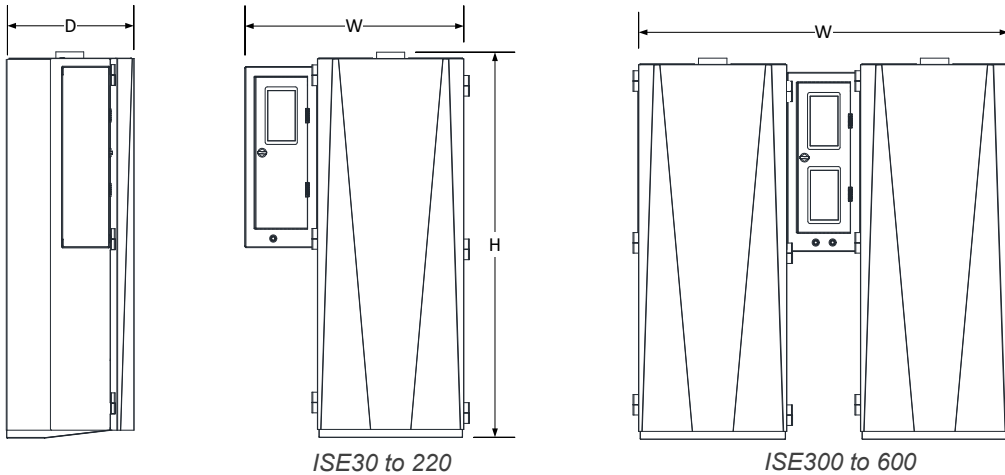

Model		ISE30	ISE70	ISE120	ISE170	ISE220	ISE300	ISE400	ISE600
Dimensions	W	508mm	711mm			1169mm		1619mm	
	H	813mm	1219mm			1219mm		1346mm	
	D	330mm	406mm			406mm		66mm	
Steam outlet	Qty	1x	1x	1x	1x	1x	1x	2x	2x
	Ø	[DN40]	[DN50]	[DN80]	[DN80]	[DN100]	[DN120]	[DN100]	[DN125]
Weight	Net	27kg	39kg			55kg		109kg	
	Oper	50kg	79kg			109kg		190kg	

## LIST OF OPTIONS

- Floor mounting rack
- Roof top weather proof enclosure (IP65)
- BACnet remote control

# ISE-HTHW

## HIGH TEMPERATURE HOT WATER

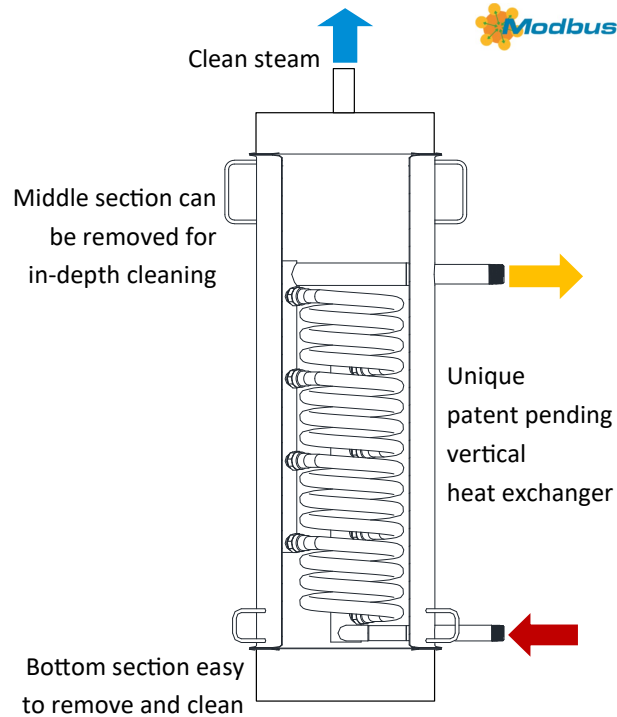

There are several advantages for HTHW boilers compared to pressurized steam boilers, such as :  
 Lower initial equipment costs ; Lower operating costs ; Higher system efficiency ; Elevation changes do not affect HTHW systems.

**ISE** steam exchange humidifier by **steamOvap®** is the perfect fit for HTHW systems, **ISE** humidifier is designed with latest technology for control and energy conservation, it is safe to operate with all components enclosed in a cabinet. Its unique vertical cylinder made of three sections is thermally insulated, allows for easy service in few minutes with no tool required. It is the only one of its kind that is truly serviceable.

- Produces pure & sterile steam
- Full and linear modulation from 1 to 100%
- Capacities from 2 to 130 kg/h
- Constant and precise steam production +/-1%RH.
- Permanent stainless steel cylinder.
- Supplied with Modbus RTU (RS485)
- Suitable for tap or RO water without additional option.
- Optional BACnet remote control.
- Board computer and 7" touch screen .
- Smallest foot print of the industry
- Self clean vertical heat exchanger with coil shape (patent pending).
- Thermally insulated cylinder

### BEST CHOICE FOR ENGINEERS

- Very efficient and safe design, as condensate cannot flood heat exchanger.
- Thermally insulated cylinder.
- Easy and versatile integration to steam network; left or right hand side connexion and standard wall mount.
- Self cleaning vertical heat exchanger made in copper + Nickel plating.

### PREFERRED BY CONTRACTORS

#### *Easiest to install*

- Smallest & lightest steam exchange humidifier of the industry.

#### *Easiest to set-up and start-up*

- Unique 7in large touch screen.

#### *Easiest to service*

- Done in minutes with no tools & absolutely no spare parts required.

### INNOVATION

- EcoEnerSmart® patented function saving energy and water.
- Unique vertical heat exchanger—patent pending.
- Internal hydraulic circuit without check valve prone to block in open or closed position.
- 7in touch screen user interface

### DESIGN & PRODUCTION

Proudly designed and made in Canada by a dedicated team combining more than 40 years of experience in humidification.



#### **Best warranty of the industry!**

*If your humidifier installation has been verified and validated (with a start-up report) by one of our authorized representatives.*



# ISE [HIGH TEMPERATURE HOT WATER]

ISE for high temperature hot water is supplied with a 3 way electric control modulating actuated valve (24Vac, signal 0-10Vdc) with fail safe,

It is also including a wall mounting bracket, water supply braided hose and drain connection sleeve DN32.

Supply voltage is 230Vac/1ph, 50/60Hz.

It has never been so easy and simple to install a steam exchange humidifier.

Thanks to its unique & patent pending vertical heat exchanger ISE is the only HTHW humidifier on the market that can use city (tap) water with a clean steam cylinder that can be opened and cleaned in minutes without the need of tool.

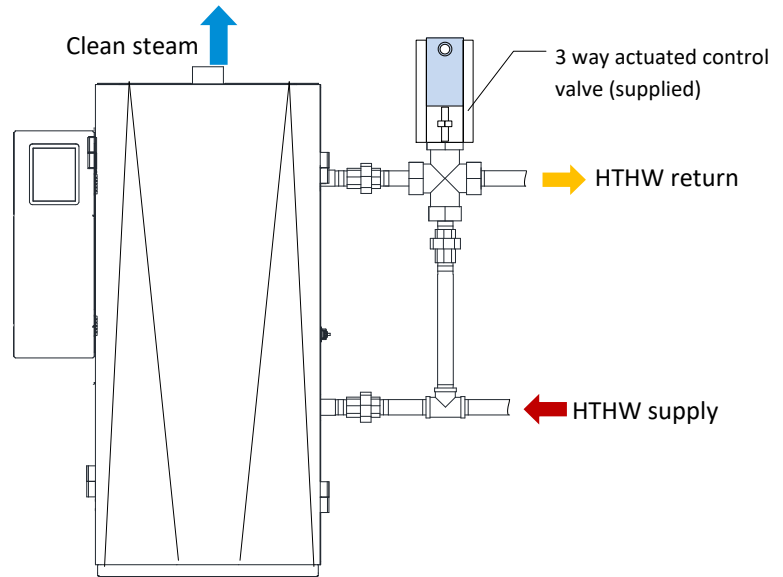

## TECHNICAL DATA [HIGH TEMPERATURE HOT WATER]

Model		ISE30-HW			ISE70-HW			ISE120-HW			ISE220-HW		
HTHW Flow (l/min)		30	45	64	30	45	64	30	45	64	30	45	64
Clean steam Capacity [kg/h] / HTHW Temp.	115°C	2	4	8	10	15	20	12	20	35	25	40	55
	125°C	13	20	25	25	30	40	28	47	55	53	68	90
	135°C	20	26	31	35	40	50	45	60	75	70	90	110
	145°C	27	30	35	40	50	60	62	78	100	89	112	130
Pressure drop (kPa)		10	15	20	20	25	30	30	45	60	30	50	70
ΔT across heat exchanger [°C]	115°C	5			5			5			5		
	125°C	8			8			8			8		
	135°C	10			10			10			10		
	145°C	15			15			15			15		
Steam outlet Qty & ø [mm]		1x DN50			1x DN50			1x DN80			1x DN100		
HTHW inlet Qty & ø [in]		1x 3/4BSP			1x 3/4BSP			1x 3/4BSP			1x 3/4BSP		
HTHW outlet Qty & ø [in]		1x 3/4BSP			1x 3/4BSP			1x 3/4BSP			1x 3/4BSP		
Cylinder Qty & Size		1x small			1x medium						1x large		

Heat exchanger is made of spiral coil copper (EN1057) with Nickel-plating protection

HTHW maximum pressure : 400kPa

HTHW inlet & outlet with flange in option.

Refer to page 13 for dimensions & weights.

## LIST OF OPTIONS

- Floor mounting rack
- Roof top weather proof enclosure (IP65)
- BACnet remote control

# STEAM DISTRIBUTION

Steam humidification is the easiest humidification method to deal with: steam is sterile so there are no hygiene concern to deal with, also there is not much risk of water carry over in the duct.

Nevertheless some basic considerations must be considered to ensure that your humidification system will be safe and efficient; with steam humidification **more is not better** : Oversizing your system will not only cause energy losses but can also lead to improper operation, early failure and in few cases condensate dripping in the supply duct.

## NON WETTING DISTANCE

Non wetting distance (NWD) is the distance downstream steam distribution at which there will be no condensing on the surfaces (except air filters or cooling coils) even if water vapour is still visible to our eyes.

Non wetting distance is dependant on the following parameters:

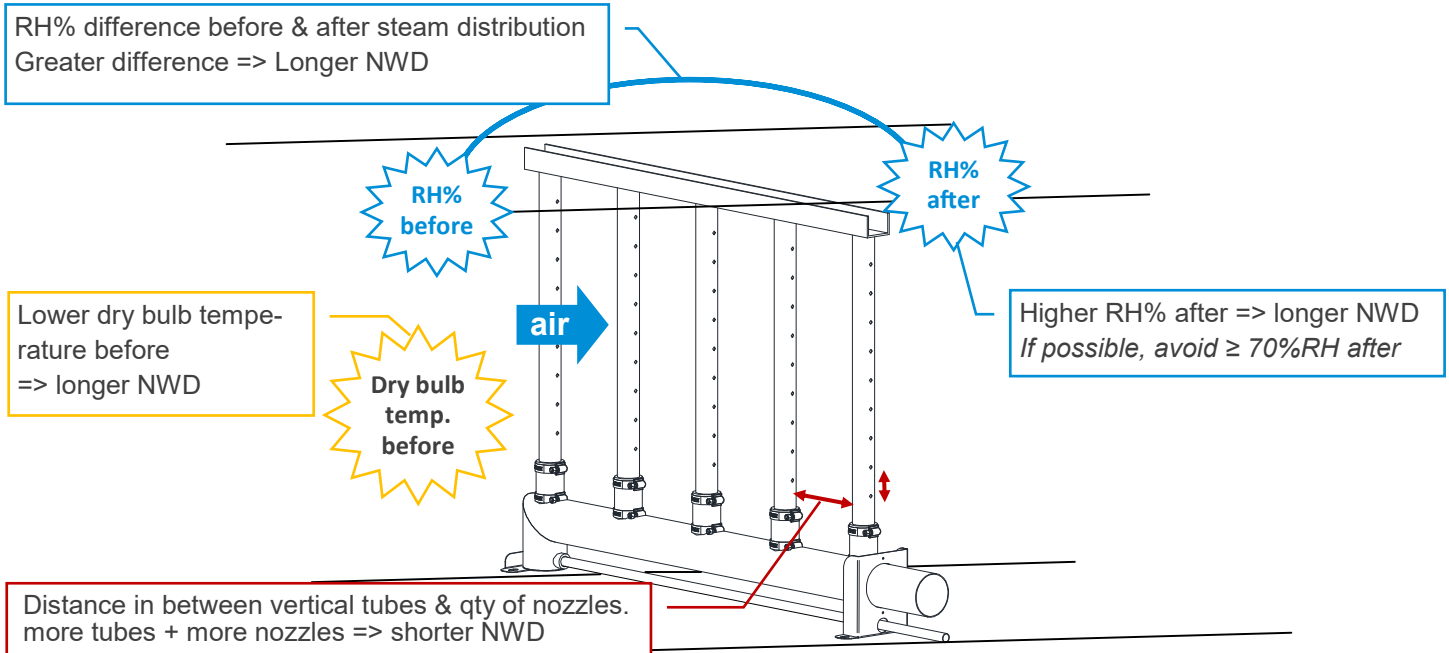

Pressure drop & quantity of condensate losses during operation will increase as more vertical tubes are added.

An efficient humidification design is not a design with the shortest non wetting distance but rather a design with the minimal losses and optimal NWD for your application.

## SELECTION GUIDE

Here is a quick guide for steam distribution in duct :

1. Define location of the steam distribution in the HVAC system  
Once the humidification load (steam capacity under the worst conditions) is defined, available distance downstream the steam distributor(s) depends on its location in the HVAC system.  
Steam distributor(s) must be placed in supply air. There are many possible valid locations in HVAC system ; however there are two locations to avoid: before air filters, or before cooling coils when cooling coils are in operation at same time as the humidifier, in both cases the steam will condense on the cold coil surfaces or in the air filter meshing.  
Best location for steam distribution is as closed as possible from the space to be humidified, and/or where air temperature is as high as possible.  
When ideal location is not possible, try to find the second best location having in mind that a short non wetting distance requirement will not only result in higher initial cost, but also in higher recurring operation costs due to more condensate losses and higher pressure drop.
2. Use **steamOcalc** our steam selection web calculator to help you find the best configuration it will indicate estimated NWD and pressure drop across the steam distributor(s) for all the possible steam distributor(s) - single horizontal ramp(s) (model **SR**) or multiple vertical tube (model **SO**) for a given humidification load and air conditions.  
When air temperature is low ( $12.8^{\circ}C$  or lower) we do recommend the use of high efficiency (**option E**) steam distribution in order to reduce the condensate losses.

As a manufacturer we will design and produce the steam distribution in order to meet your required NWD. However, as designer avoiding very large increase of RH% or low air dry bulb temperature will greatly affect the quantity of required vertical tubes thus the cost of the steam grid and its efficiency (condensate losses and pressure drop of the steam grid).

# DECISION TREE

Method	In duct		In space	
Type	Single ramp		Distribution grid	
Model	<b>SRS</b>	<b>SRC</b>	<b>SO steamOsorb</b>	
Diameter	[DN40, 50 or 65]	[DN40, 50 or 65]	Header SO-H [DN50 to 200]	Vertical ramp SO-R [DN40 or 50]
Capacity	2 to 30kg/h	2 to 38kg/h	2 to 1500kg/h	
Distance between ramps	As per duct height & qty, min. 76mm	As per duct height & qty, min. 76mm	As per duct width and required NWD, minimum 76mm	
Options	2 rows of nozzles (option X) Thermal insulation (option E)		Thermal insulation (option E) Frame with flanges (option FF) Frame for Insertion (option FI)	

## SINGLE RAMPS

### SRS - STEAM RAMP

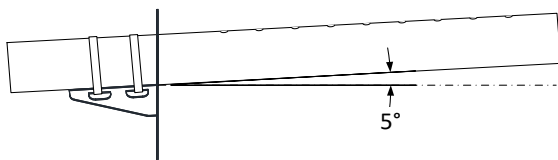

**SRS** - Steam ramp without dedicated condensate return  
Condensate is returned in same steam pipe, with the 5° slope.  
Simpler to install, but not recommended when large quantity of condensate is produced, in case of long steam line run or large duct with low air temperature.

-V for Vertical flow and/or -R for Round duct.

### SRC - STEAM RAMP

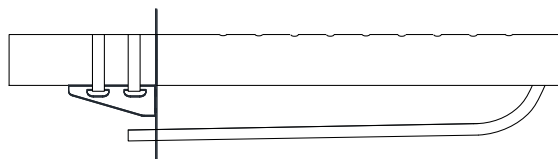

**SRC** - Steam ramp with dedicated condensate return  
Condensate is returned in a dedicated pipe. This allow to carry more steam in steam line.

This design avoids any possible trouble due to condensate flowing against the steam flow inside steam line. A condensate line must be installed and connected to drain or returned to humidifier.

-V for Vertical flow and/or -R for Round duct.

### OPTION X

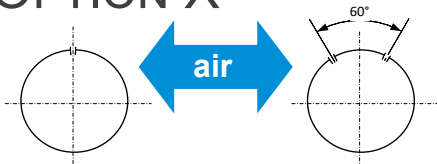

**SRSX or SRCX** - single steam ramps with 2 rows of nozzles

This option allows for more steam capacity for the steam ramps.

It reduces the required quantity of steam ramps when one ramps is not enough to distribute the steam capacity.

Two rows of nozzles would not reduce non wetting distance.

### HORIZONTAL DUCT

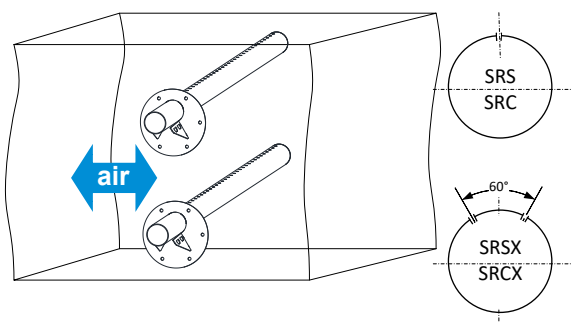

### VERTICAL DUCT

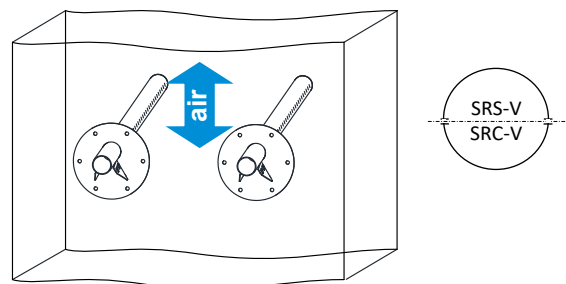

# STEAMOSORB MULTI-RAMPS

## SOS - STANDARD STEAMOSORB



- Integral stainless steel construction.
- Made to measure to fit duct or AHU dimensions.
- Fits horizontal or vertical flow duct.
- Achieve very short non-wetting distance.
- 3 year warranty.

Model **steamOsorb** is made of vertical tubes equipped with steam distribution nozzles. These nozzles are positioned perpendicular to the air flow; the tubes are connected to the header which is provided with a condensate return pipe and two feet. A top mounting bracket completes the assembly to maintain the vertical tubes and allow for easy installation of the **SO** in the ventilation duct or AHU.

Each **SO steamOsorb** is designed and adapted to fit inside ventilation duct and to meet the calculated non-wetting distance; header diameter will depend on maximum steam capacity; quantity of vertical tubes and quantity of nozzles will depend on steam capacity and non-wetting distance.

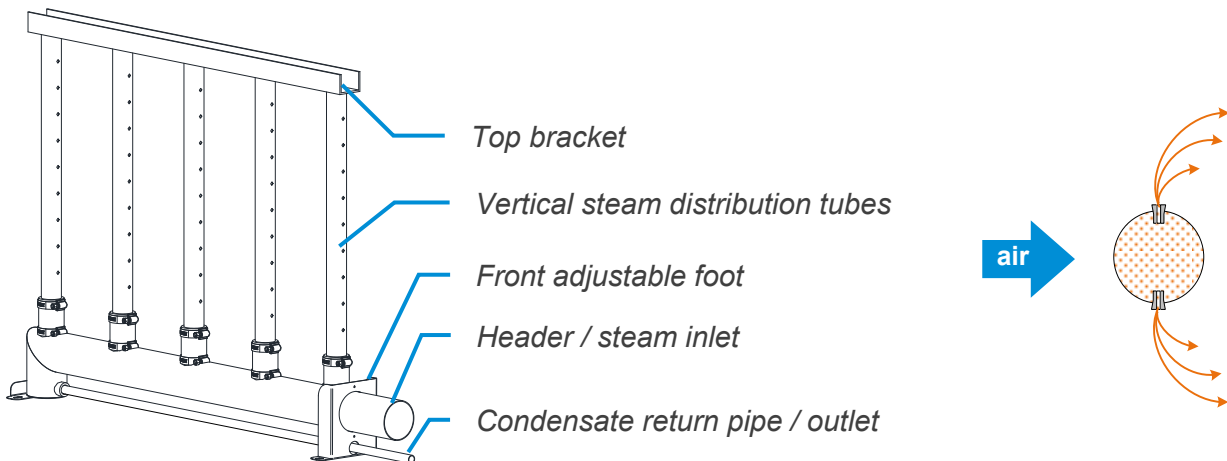

Standard mounting is by seating the **SO steamOsorb** inside the duct. The front and back foot bracket are attached duct bottom plate and top bracket is attached to the top plate of the duct,

In some cases, for large steam capacity into small duct and/or very short non-wetting distance requirements, mounting **options -FF** (Frame with flanges) or **-FI** (Frame for insertion) will allow to place the steam header outside the duct.

Frame for **-FF** & **-FI** are made of stainless steel and are adapted to the exact size of your duct.

### OPTION - FF

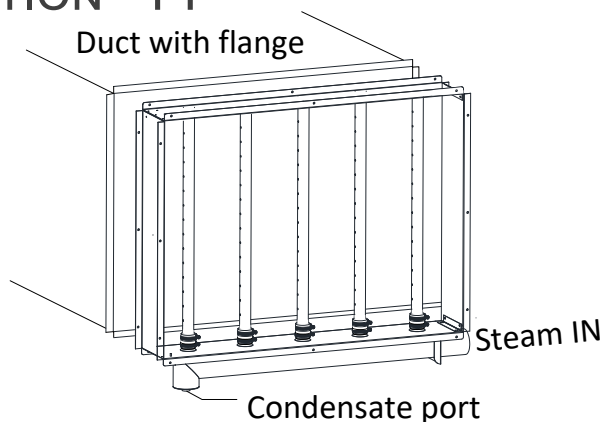

### OPTION - FI

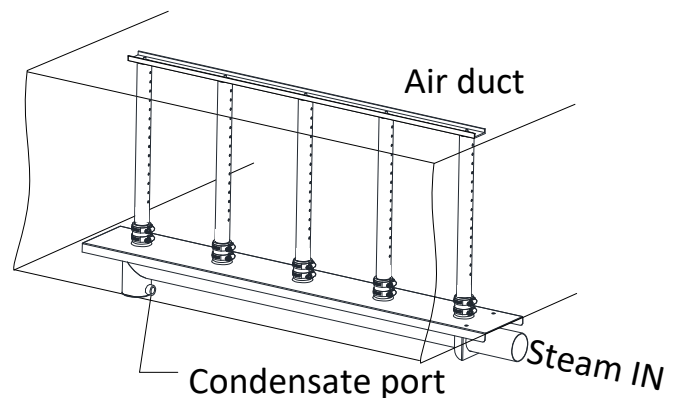

# HIGH EFFICIENCY STEAM DISTRIBUTION

## OPTION E

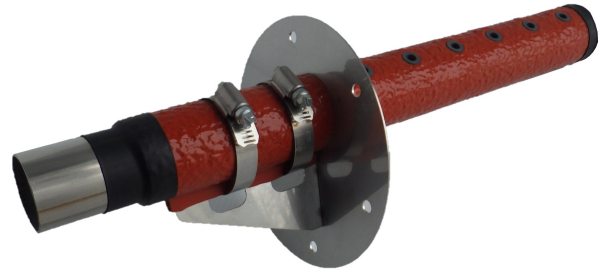
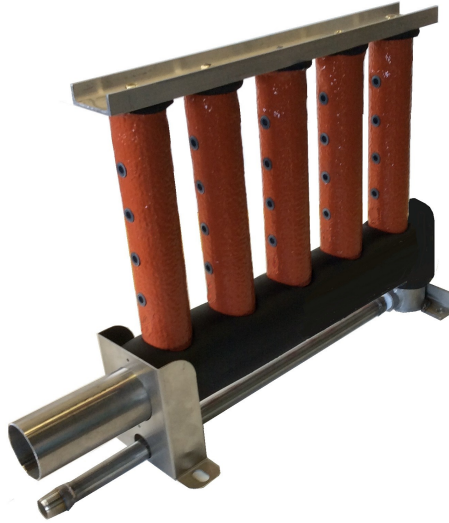

**High Efficiency** steam ramps with thermal insulation - **option E** - is available on any steam ramp model, single ramp, model **SRS**, or **SRC**, or steamOsorb multi-ramps, model **SO**.

This solution combines two very efficient and robust insulation materials in hollow sleeve with no longitudinal joint. It is covering all parts in contact with cold air. This thin thermal insulation is allowing to significantly increase efficiency by reducing condensate loss and air heat gain. It is a proven and affordable design.

Insulation material is rated for direct contact with flame and a 260°C continuous operation, UL rated, certified to ASTM E84 (equivalent to UL723) and bearing more safety certifications than any others.

- Dramatically reduces condensate losses in steam ramp. Up to 80% increased efficiency.
- Allow very short absorption distance of steam .
- Excellent thermal resistance Calculated R value = 0.33
- Thin insulation 3.6mm.
- Available for atmospheric steam or live steam and for single or multi ramps.
- Higher steam capacity per ramp.
- Rated for 260°C continuous operation.
- Minimal pressure drop, no obstruction in duct.
- Resistant to molten metal, flames, abrasion, corrosive atmosphere, moisture, chemicals and more.
- Certified to ASTM E84 (equivalent to UL723).
- Drip free nozzles made of polymer.
- No risk of damage during installation or during the life of the humidifier.



### Best warranty of the industry!

*If your humidifier installation has been verified and validated (with a start-up report) by one of our authorized representatives.*

### SAVE ENERGY - SAVE MONEY

- Reduce wasted energy from steam condensation up to 80%  
= less energy required for same designed steam capacity  
= saving money for operation.
- More capacity allowed for steam ramp  
= shorter and/or fewer steam ramps for same steam capacity  
= saving money for acquisition.
- Reduced heat gain of air upon free cooling season  
= reduced amount of cold outdoor dry air  
= reduced required humidification load  
= saving money for operation.

### ROBUST DESIGN - NO THERMAL BRIDGE

**steamOvap®** high efficiency thermal insulation is made of two components:

- Fiberglass braided hollow sleeve offering optimal thermal resistance with steam ramp.
- Iron oxide red silicone rubber outer shell with exceptional chemical, abrasion, UV and moisture resistance, ensuring robust and risk free damage during onsite installation.

Unless all of the other solutions offered today to the HVAC industry, **steamOvap®** high efficiency thermal insulation is a round sleeve which do not have longitudinal joint causing thermal bridge and premature degradation.

# STEAM DISTRIBUTION

## SB - SPACE BLOWER



- Thermally insulated steam diffuser made of stainless steel - unique to the industry.
- Adjustable air flow deflector.
- Built-in or remote mounting from IER or ISE humidifiers.
- Washable inlet air filter.



### Best warranty of the industry!

If your humidifier installation has been verified and validated (with a start-up report) by one of our authorized representatives.

**SB** - Space blower allows for direct in-space steam distribution when no ventilation duct is present or for humidification at a very specific location.

Space blower can be factory installed built-in on the **IER** or **ISE** humidifier or on-site installed remotely from the humidifier.

**SB** is robust and unique to the industry as the stainless steel steam distributor is thermally insulated in order to reduce condensate loss and optimize steam output. It also reduces temperature of all the internal components during operation increasing the life expectancy of the electrical motor fan.

## TECHNICAL DATA

Model	SBS	SBM	SBL
Steam inlet Diam.	[DN40]	[DN50]	[DN65]
Max capacity	12.0kg/h	29.0kg/h	44.0kg/h
Dimensions WxHxD (cm)	23x18x23	29x23x30	29x23x30

## MOUNTING CONFIGURATION

### BUILT-IN

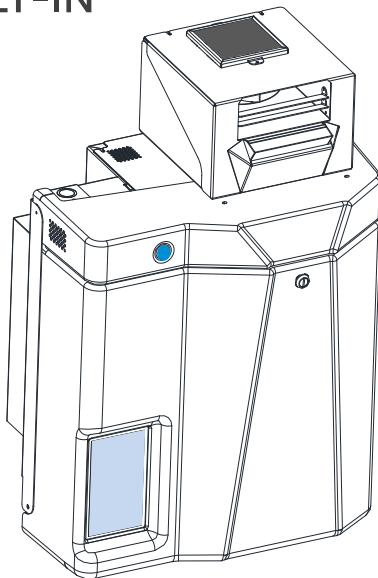

Power supply from humidifier **IER** or **ISE**

### REMOTE

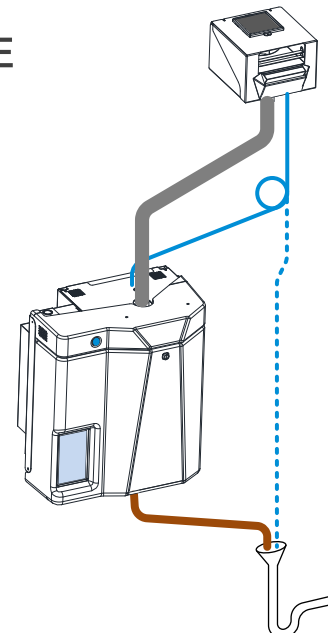

Supplied with 230Vac/1ph power cord and outlet adapted to country's standard receptacle

# ENGINEERED SOLUTIONS

---

## STAND ALONE HUMIDIFIER WITH RO FILTRATION



This solution is ideal for Marijuana growing rooms or application where the need for humidification is temporary.

It is including on a floor stand easy to move:

- **IER** electric steam humidifier
- Built-in **SB** space blower
- **WRO** water filtration with storage tank.
- **RHS** humidity sensor

With this integrated solution installation of the humidifier has never been so simple: connect water supply to RO filter, drain connection and electrical connection with a single point of connexion.

In some marijuana growing facility where the plants are not moved from one room to the others depending on the stage of growth have to plan for very different air conditions to adapt to the development of their plants.

They need to add-on humidity in the air at the early stage of the growing. Then when the plants are mature enough there is no more need for humidifying but rather to de-humify the air. Our stand alone unit can then be moved away to another room.

---

## RT - WEATHER PROOF ENCLOSURE



**RT** weather proof enclosure for **IER** or **ISE** humidifier has been designed to be very robust and versatile. It is including the following features:

- **IP65** ingress protection rating (equivalent to NEMA type 4).
- Made of stainless steel - there is no risk of rust or ageing over time. Stainless steel is also reflecting the sun radiation in hot climate region.
- Designed for installation on a **roof curb** or a **stand** or **wall** mounting without any additional option or special order or change on site.
- Connections for steam outlet, water supply and drain can be in the back or side of the enclosure.
- Thermally insulated, **heated** and **ventilated** enclosure to protect for extreme outside conditions.
- All access for regular service from the **removable front door**.
- 7in touch screen control panel built-in on the side or remote (typically inside the building).
- Proven design with many seasons of operation under Middle-east sun and severe Canadian winters.

Contact us if you have a specific application or a problem related to humidity level to maintain.

[info@steamovap.com](mailto:info@steamovap.com)

# LIVE STEAM HUMIDIFICATION

Live steam humidification is a very efficient and cost effective way for air humidification when pressurized steam is available on site. Some precautions and good design practices must be considered:

1. Pressurized steam supply must be free from harmful chemical; please refer to FDA - Code of Federal Regulations Title 21, Sec. 173.310 Boiler water additives, regarding the type and amount of additives that may be safely used in the preparation of steam for human consumption.
2. Pressurized steam should be conditioned before to be injected into the air stream. The use of a strainer and a steam separator as well as a properly sized steam valve ensure smooth and safe operation.
3. It is a good design practice to limit steam pressure in a range of 34 to 103kPa. Below 34kPa pressurized steam efficiency is limited, increasing the size of the component and cost. Above 103kPa there is a risk of cavitation in the control valve and there will be a need for high pressure components or addition of pressure reducing valve.

The selection guide below will help you select among our different **ILS** models and options.

## SELECTION GUIDE

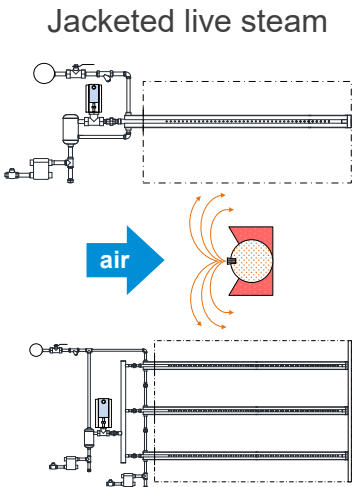
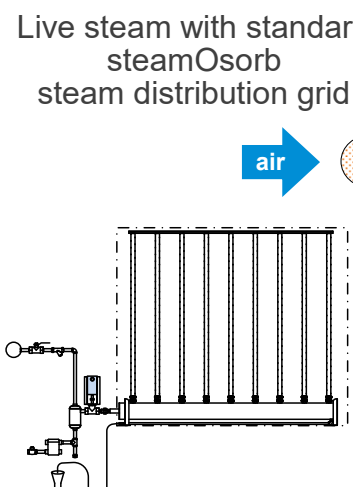
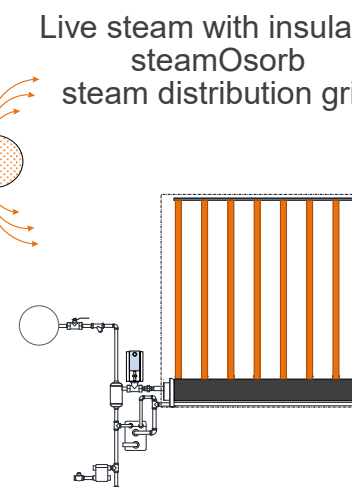
	<b>ILS-P</b> Jacketed live steam	<b>ILS-SO</b> Live steam with standard steamOsorb steam distribution grid	<b>ILS-SE</b> Live steam with insulated steamOsorb steam distribution grid
<b>Model</b>			
<b>Heat Gain</b>	Large heat gain in the air stream Best use when humidification is required only in winter	Some heat gain in the air stream Best use when humidification is required only in winter	Very limited heat gain in the stream All year long humidification, i.e. also when cooling is ON.
<b>Condensate Handling Option</b>	Large amount of condensate Pressurized condensate returned to boiler n/a	Good amount of condensate Atmospheric condensate to drain Optional pressure motive pump (model <b>PMP</b> ) can pressurize atmospheric condensate and lift it back to the boiler	Very few condensate
<b>Capacity Range Limit</b>	2 to 1,500kg/h or more Single ramp best adapted for small capacity	2 to 1,500kg/h or more Not adapted for small capacity	
<b>Non-wetting distance (NWD)</b>	Very short	Steam distribution grid is fully adaptable to NWD requirements	
<b>Duct Dim. Options</b>	Small to large duct dimensions n/a	Best adapted for medium to large duct dimensions Options - <b>FF</b> & - <b>FI</b> with header below and outside the duct for large steam capacity with shorter NWD	
<b>Initial cost</b>	Moderate initial cost	Lowest initial cost	Highest initial cost
<b>Other options</b>	Integral stainless steel construction for pure steam (boiler supplied with DI water). Steam control valve with stainless steel trim and seal or PTFE seal material are available.		





**ILS** humidifier by **steamOvap®** uses steam from a central steam boiler as a source of humidity for air duct or air handling unit.

The **ILS** includes all the components required for the treatment and conditioning of low pressure steam.

Its integral stainless steel construction of grade 304 and its robust design makes the **ILS** the humidifier by excellence in its category.

When low pressure clean steam is available on site it is the most economical and effective way to provide humidification meeting any capacity requirement.

- Capacities from [2 to 1500kg/h.
- Cost effective humidification for medium to large load.
- Designed to use steam from boiler operating with DI, RO or tap water.
- Drip free steam guaranteed, and very short non wetting distance
- Supplied with strainer, separator, fully modulating electric actuated valve with fail safe and Float & thermostatic steam trap.
- Optional thermo-contact for F&T steam trap
- Optional Condensate drain cooler for **ILS-SO** and **ILS-SE**



**Best warranty of the industry!**

*If your humidifier installation has been verified and validated (with a start-up report) by one of our authorized representatives.*

### ILS HUMIDIFIER OVERVIEW

**steamOvap®** is offering a full and complete range of Live steam humidifier solutions:

**ILS-P** is our pre-heated jacket model. Where steam is circulating into the jacketed tube before to pass through the steam separator and being distributed into AHU or the air duct. **ILS-P** is declined in 3 types:

- **Single ramp**
- **Mini rack**  
(factory assembled)
- **Horizontal Multi-ramp**  
(on-site assembly)

**ILS-SO** is our **steamOsorb** vertical multi-ramp model.

**ILS-SE** is the high efficiency **steamOsorb** vertical multi-ramp model.

With any of the **ILS** model you are sure to get a superior and robust solution that will be easy to select, install and operate for many years to come.

### STEAM COMPONENTS SUPPLIED

- Bronze body control valve with brass or S/S trim or optional full S/S construction
- Electric (24Vac) fully modulating (2-10 or 0-10Vdc) actuator with fail safe
- S/S steam separator
- Cast iron body with S/S strainer
- Cast iron body with S/S trim Float & Thermostatic steam trap , H type
- Steam jacketed steam ramp made of stainless steel

### LIST OF OPTIONS

- Condensate drain cooler with thermostatic valve or electric
- S/S body control valve, S/S body strainer.
- Thermo contact for F&T steam trap
- Manual or actuated shut-off valve for steam supply .
- Pressure motive pump for condensate lifting.
- BACnet remote control.

# ILS-P

## LIVE STEAM HUMIDIFIER (JACKETED)

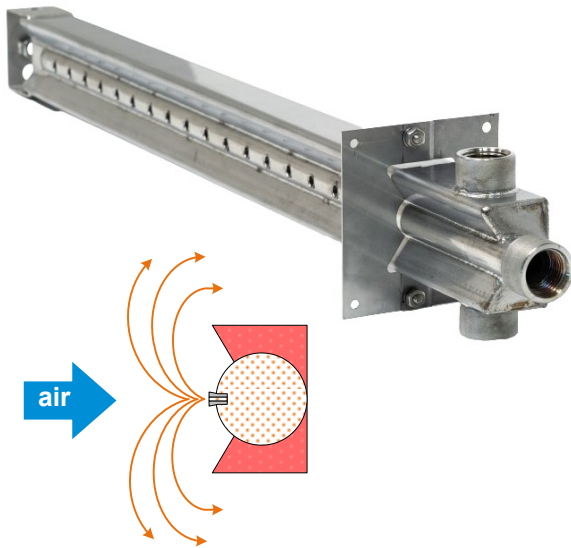

**ILS-P** humidifier by **steamOvap®** is using steam ramp with a pre-heated jacket. Steam is circulating into the jacketed tube before to pass through the steam separator and being distributed into AHU or the air duct.

The **ILS-P** includes the following components: strainer, separator, actuated control valve, steam ramps with pre-heated jacket and F & T condensate trap.

This old technology is still the best suited solution when clean steam from central boiler is available on site and humidification requirement correspond to the heating season, as the huge heat gain from the steam jacket will contribute to air heating. Steam injection against the air flow is ensuring a very short non wetting distance.

- Capacities from 2 to 1500kg/h.
- Very cost effective humidification for medium to large load.
- Designed to use steam from boiler operating with DI, RO or tap water.
- Drip free steam guaranteed, and very short non wetting distance
- All configurations are available: Single or Mini kit and horizontal Multi-ramp.
- Supplied with fully modulating electric actuated valve (24vac, signal 0-10 or 2-10Vdc)
- Optional thermo-contact for F&T steam trap

### SINGLE RAMP

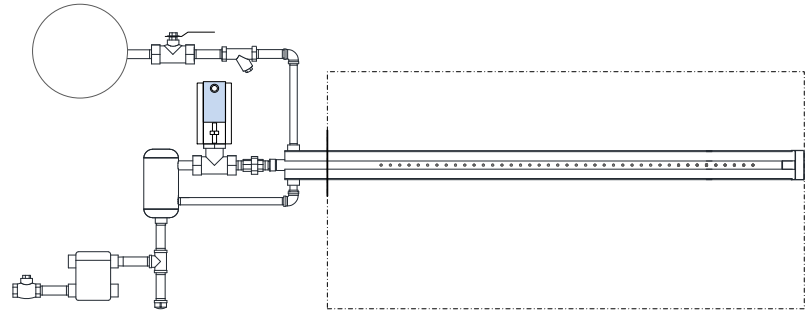

**Single ramp** type provides lowest initial investment cost for steam humidification.

Capacity from 2 to 150kg/h.

### MINI-KIT

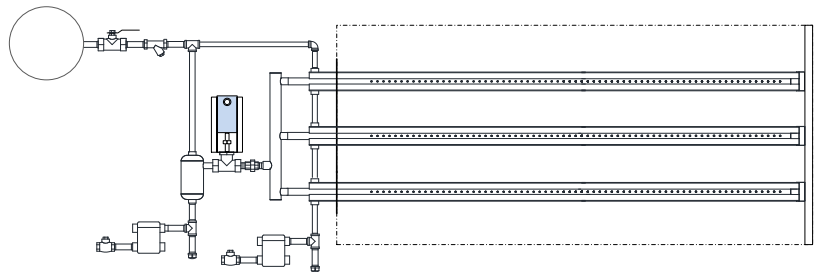

**Mini kit** (factory assembled) provides a compact design.

Capacity from 2 to 150kg/h.

### MULTI-RAMPS (HORIZONTAL)

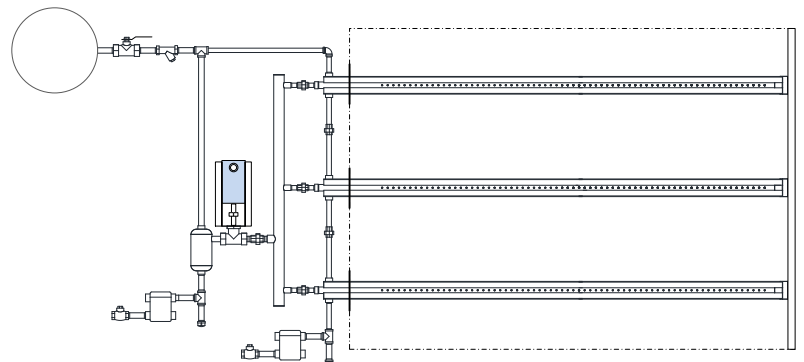

**Horizontal multi-ramp** (on-site assembly) is the best option for large AHU.

Capacity from 2 to 1500kg/h.

# ILS-SO

## LIVE STEAM HUMIDIFIER (STEAMOSORB)

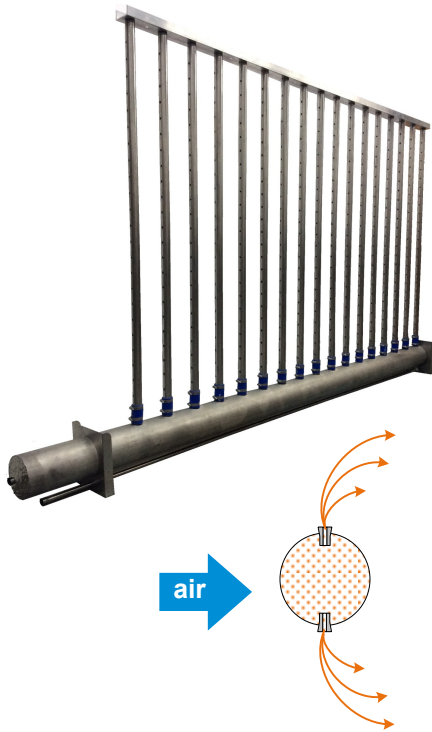

### VERTICAL MULTI-RAMP - ATMOSPHERIC CONDENSATE

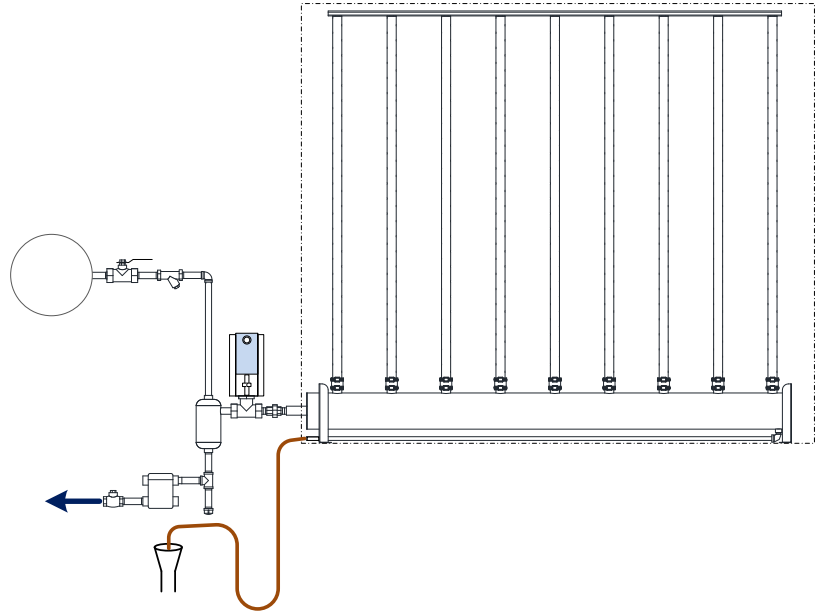

Condensate is atmospheric and returned to main drain of the building.  
Optional condensate drain cooler with thermostatic or electric valve.

### VERTICAL MULTI-RAMP - PRESSURIZED CONDENSATE

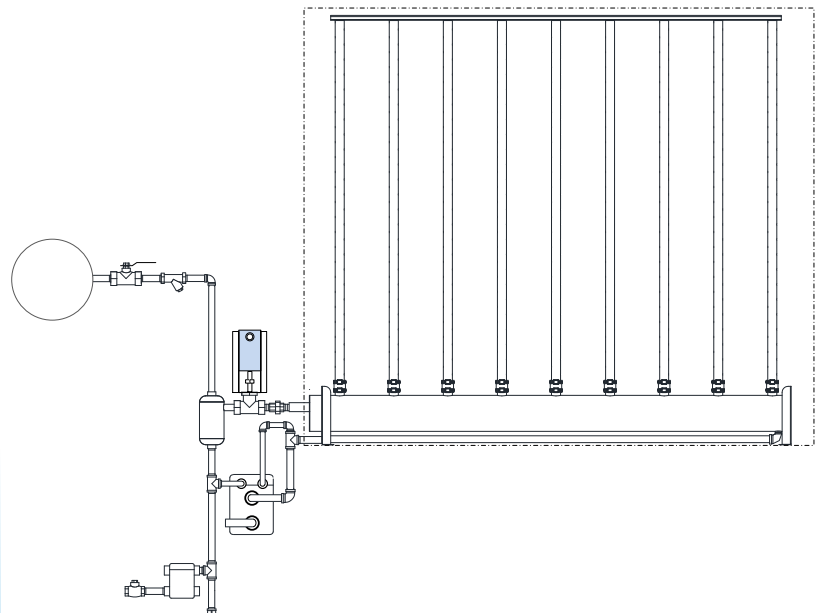

Condensate collected in the header is re-pressurized with pressure motive pump and returned to the boiler. 0 waste to drain.

**ILS-SO** humidifier by **steamOvap®** is using vertical steam ramp.

Any condensate forming in the steam ramp will fall and collect into the large horizontal header, before to be directed to the drain or re-pressurized with pressure motive pump.

Drip free steam distribution is ensured by the special design of the nozzles.

It is a simple and very cost effective way to humidify when pressurized clean steam is available on site and humidification requirement correspond to the heating season, as the huge heat gain from the steam ramps will contribute to air heating.

- Capacities from 2 to 1500kg/h.
- Very simple to install and cost effective humidification for small to large load. AHU manufactured preferred.
- Designed to use steam from boiler operating with DI, RO or tap water.
- Atmospheric or pressurized condensate return available
- Supplied with fully modulating electric actuated valve (24vac, signal 0-10 or 2-10Vdc).
- Optional thermo-contact for F&T steam trap.
- Optional BACnet remote control.

# ILS-SE

## LIVE STEAM HUMIDIFIER (HIGH EFFICIENCY STEAMOSORB)

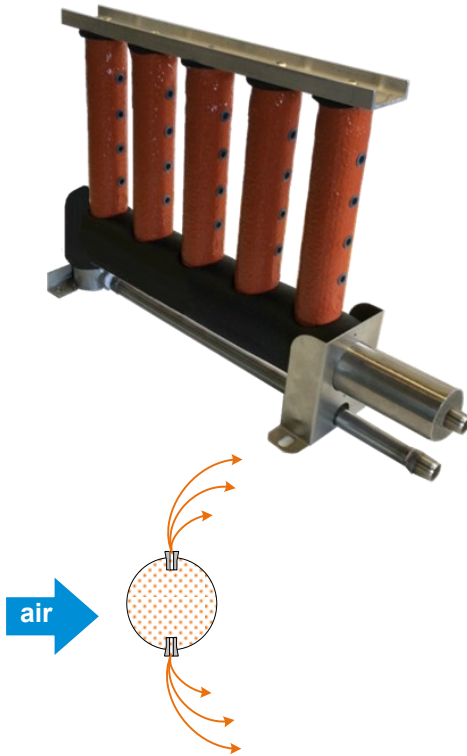

### VERTICAL MULTI-RAMP - ATMOSPHERIC CONDENSATE

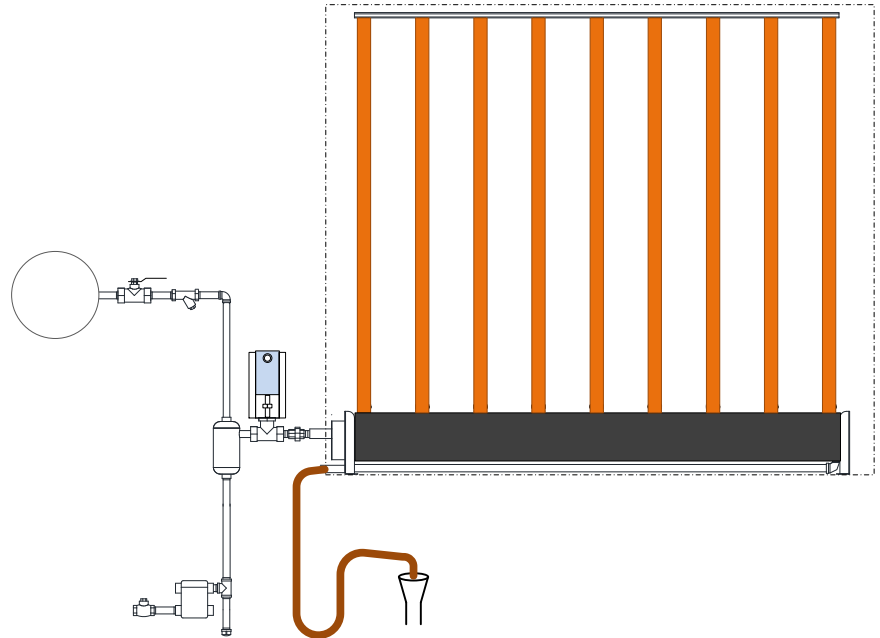

Condensate is atmospheric and returned to main drain of the building.  
Optional condensate drain cooler with thermostatic or electric valve.

### VERTICAL MULTI-RAMP - PRESSURIZED CONDENSATE

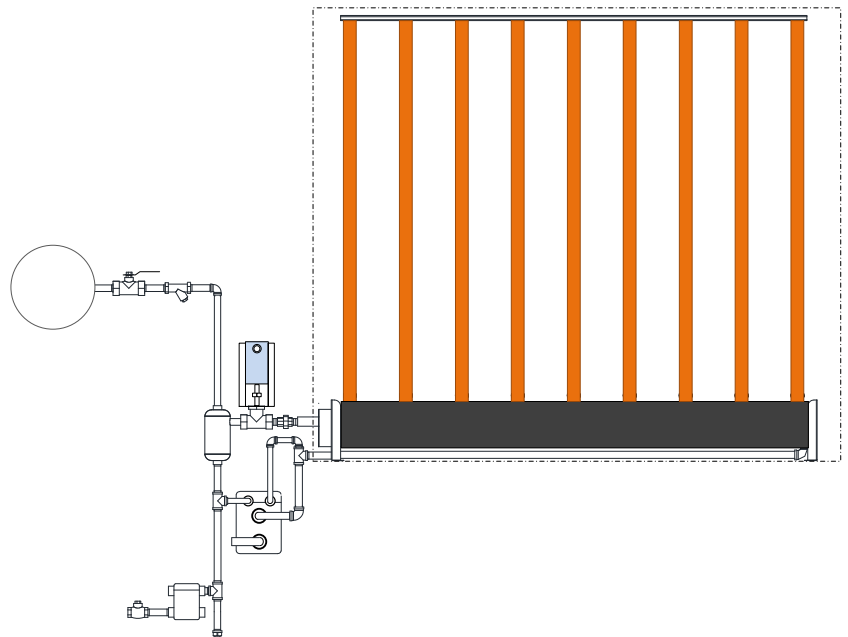

Condensate collected in the header is re-pressurized with pressure motive pump and returned to the boiler. 0 waste to drain.

**ILS-SE** humidifier by **steamOvap®** is using thermally insulated vertical steam ramps. This model combines the proven and simple Live steam humidification with latest sustainable developments. The very few condensate forming in the steam ramp will fall and collect into the large horizontal header, before to be directed to the drain or re-pressurized with pressure motive pump. Drip free steam distribution is ensured by the special design of the nozzles. Heat gain to air flow is minimal so it is a good humidification solution for year round humidification requirement.

- Capacities from 2 to 1500kg/h.
- High efficiency with **robust** very thin thermal insulation covering **all** parts in contact with air.
- Rated for 260°C continuous operation & certified ASTM E84 (eq. UL723)
- Atmospheric or pressurized condensate return available
- Supplied with fully modulating electric actuated valve (24vac, signal 0-10 or 2-10Vdc)
- Optional thermo-contact for F&T steam trap
- Optional BACnet remote control

# TECHNICAL DATA

Model	ILS-P single ramp	ILS-P mini-kit	ILS-P multi-ramp	ILS-SO	ILS-SE
Capacity	2 to 150kg/h	2 to 150kg/h	2 to 1500kg/h	2 to 1500kg/h	2 to 1500kg/h
Steam pressure	13 to 103kPa	13 to 103kPa	13 to 103kPa	13 to 103kPa	13 to 103kPa
Distance between ramps	n/a	76mm	150mm	76mm	76mm
Actuated valve (voltage & signal)	24Vac 0-10 or 2-10Vdc	24Vac 0-10 or 2-10Vdc	24Vac 0-10 or 2-10Vdc	24Vac 0-10 or 2-10Vdc	24Vac 0-10 or 2-10Vdc

## NOMENCLATURE ILS-P

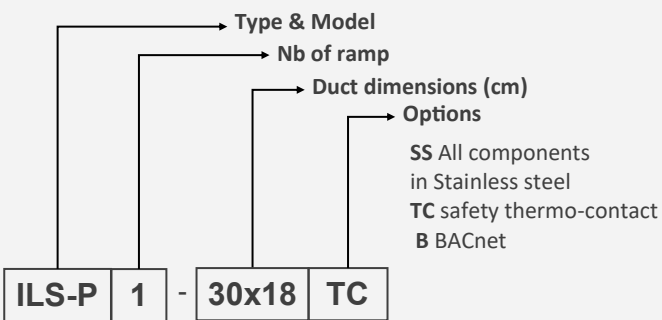

## NOMENCLATURE ILS-SO/SE

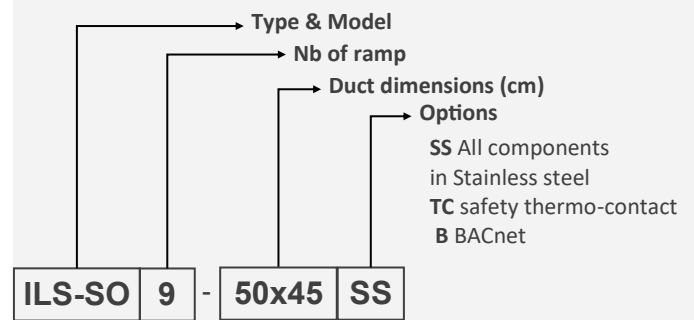

## CONFIGURATIONS & STEAM COMPONENTS

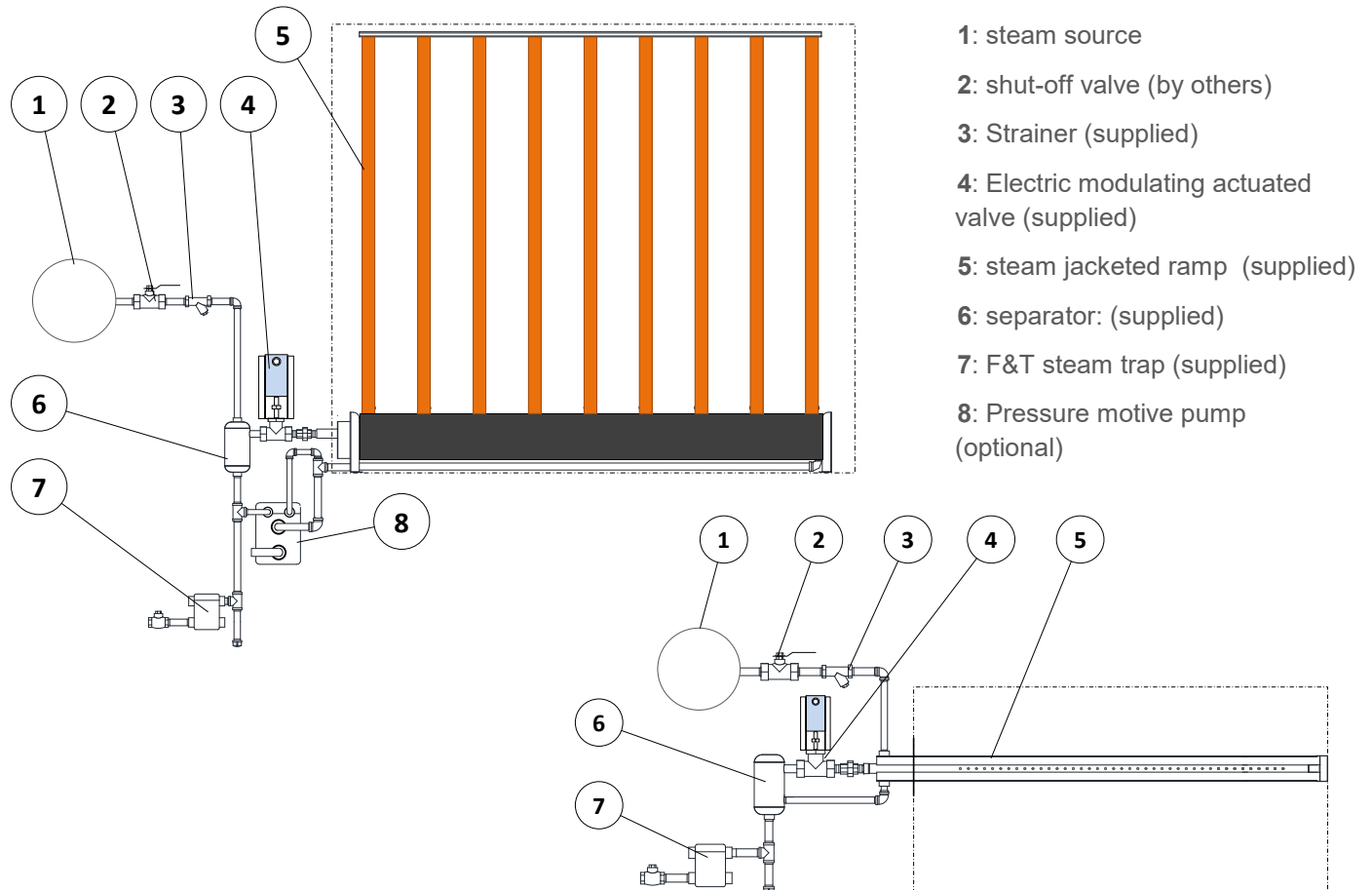

# PSYCHROMETRIC CHART

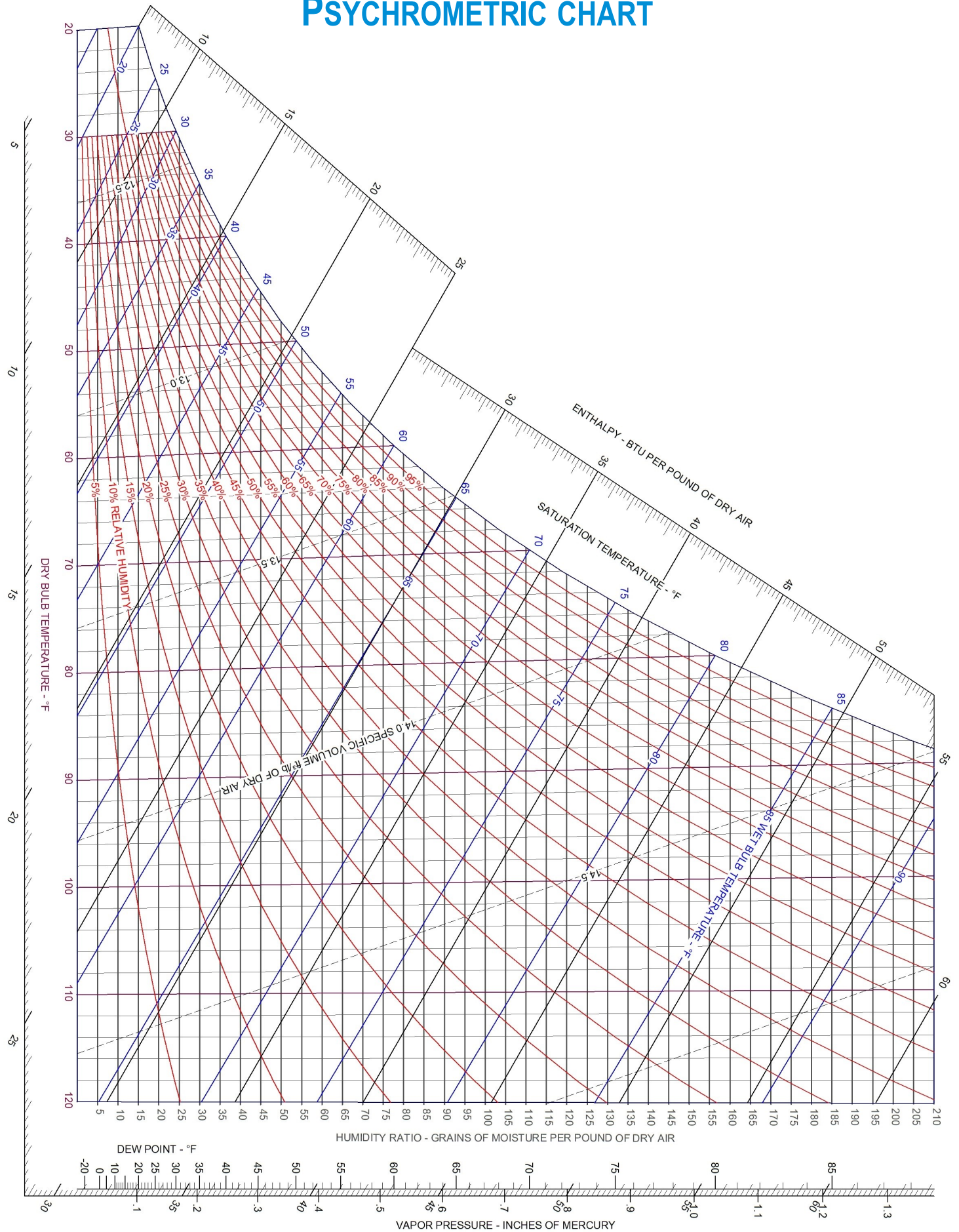

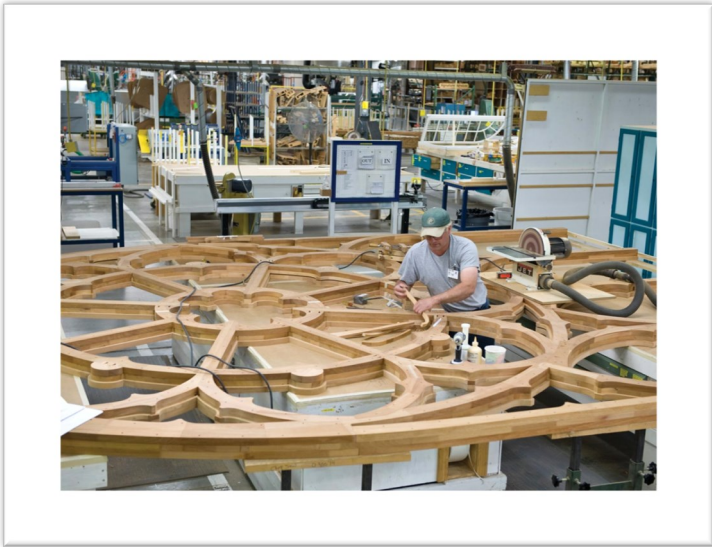

# ADIABATIC HUMIDIFIERS & AIR COOLERS

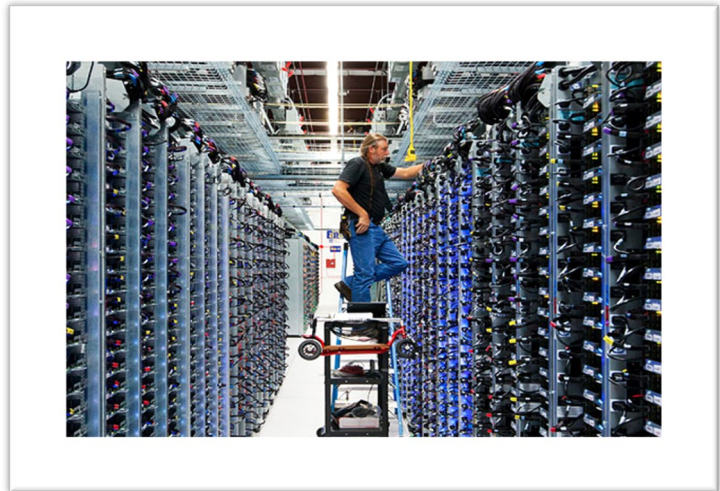
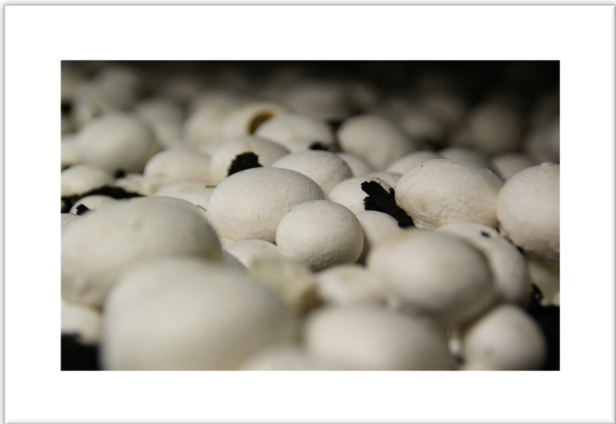
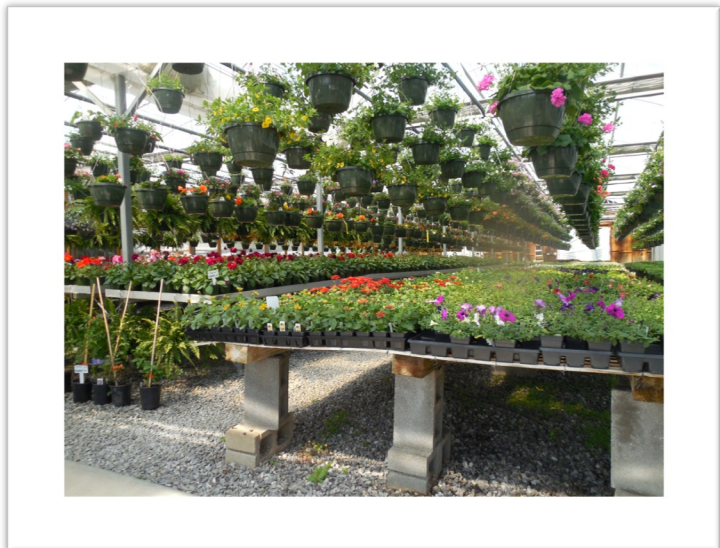

# AUL01

## ULTRASONIC HUMIDIFIER

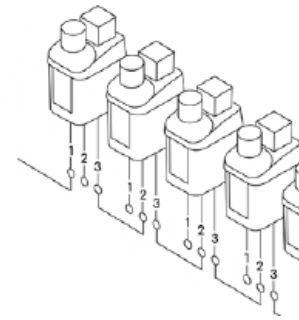

Master/slave

**AUL01** ultrasonic humidifier is nebulizing water into micro particles producing a dry fog that is quickly absorbed by the surrounding air.

**AUL01** is a perfect solution for compact and modular ultrasonic humidification. It generates humidity by breaking up the molecules of the water contained in the reservoir and producing mist through the energy transferred by ultrasonic ceramic transducers. The mist (humidity) is introduced into the space via a rigid tube.

Ultrasonic humidifiers are best suited for agro-food storage room or refrigerated display and bank, cold room, wine cellar, humidior, or for the humidification of HVAC applications such as fan coils or computer / server room.

**AUL01** can accept untreated water, however the use of RO treated water is recommended to avoid the dispersion of fine solid particles contained in tap water.

- Capacity of 1.0kg/h per module producing 0.5µm water mist.
- High accuracy +/-1%RH. & high humidity: up to 96%RH.
- Ideal for humidification at low temperature - up to 0°C
- Modular design and master/slave operation.
- Safe operation with 24Vac power supply and water leakage protection.
- Smallest footprint of the industry
- Modbus RTU remote communication.
- Optional remote controller with touch screen, or WiFi connectivity, or BACnet.

### DIRECT IN SPACE

In direct in-room configuration the **AUL01** humidifiers consists of the following components:

- Ultrasonic module equipped with air circulation fan
- Mist distribution pipe kit that can be easily adapted on site.
- In room RH% sensor
- Optional remote controller.

### IN DUCT

For In-duct configuration the **AUL01** (without air circulation fan) will be prepared so it is easy to install on the side of the duct.

- Special air intake and mist distribution piping kit.
- In duct RH% sensor.
- Optional remote controller.

### HYGIENIC

**AUL01** is equipped with drain valve. Automatic and regular drain cycle are performed to ensure that water cannot be stagnant in the tank.

Air inlet is filtered to avoid water contamination from air particles and bacteria.

### INNOVATION

Most versatile modular configuration and installation.

Modbus RTU connection as standard

Optional Touch screen controller

Optional WiFi connectivity



### Best warranty of the industry!

If your humidifier installation has been verified and validated (with a start-up report) by one of our authorized representatives.



# VERSATILE APPLICATIONS

## HVAC industry

Server room or data center CRAC  
Office or residential small AHU  
Fan coil integrated humidifier

## Retail industry

Vegetables refrigerated counters  
Meat or Deli refrigerated counters  
Cheese counter  
Humidor

## Agro food industry

Marijuana growing rooms  
Wine cellars  
Meat ageing rooms

## TECHNICAL DATA

Model	AUL01	AUL02	...	AUL10	...	AUL16
<b>Capacity</b> (lb/h) [kg/h]	1.0	2.0		10.0		16.0
<b>Power</b> (W)	110W	220W		1100W		1760W
<b>Supply voltage</b> (Vac/ph-freq)	100 to 240Vac / 1ph - 50/60Hz	100 to 240Vac / 1ph - 50/60Hz		100 to 240Vac / 1ph - 50/60Hz		100 to 240Vac / 1ph - 50/60Hz
<b>Water pressure</b> (PSI) [kPa]	20 to 100kPa	20 to 100kPa		20 to 100kPa		20 to 100kPa
<b>Water conductivity</b> ( $\mu$ S.cm)	0 to 1250 max	0 to 1250 max		0 to 1250 max		0 to 1250 max
<b>Nb of module</b>	1	2		10		16

Supplied with 100-240Vac power supply, wall mounting bracket, water supply braided hose and drain hose.

**Kit D** (in Duct humidification), supplied with PVC air duct and air filter.

**Kit S** (in Space humidification), supplied with air inlet fan and air filter.

## TECHNICAL DRAWINGS

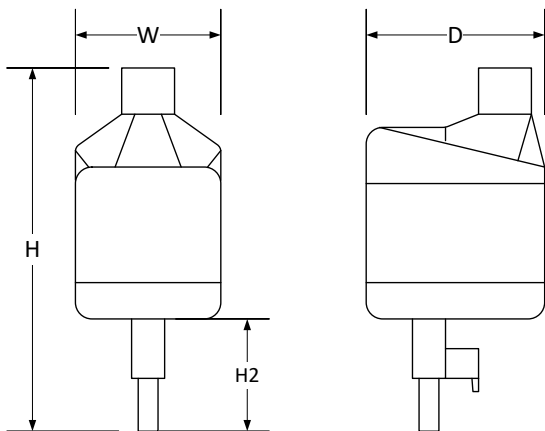

Model	Dimensions (cm)				Net Weight
	W	H	H2	D	
AUL01	10.8	26.3	6.5	14.8	1.6kg
AUL02	21.6	26.3	6.5	14.8	3.2kg
AUL10	108.0	26.3	6.5	14.8	16.0kg
AUL16	173.0	26.3	6.5	14.8	25.6kg

## NOMENCLATURE

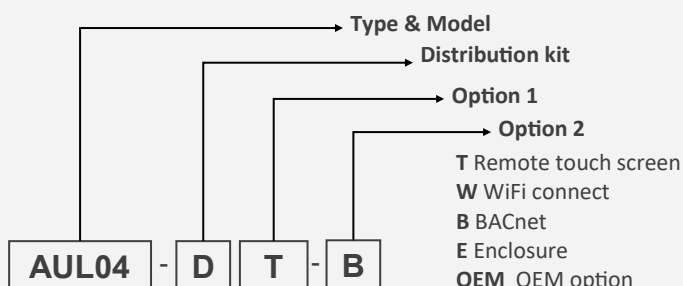

## LIST OF OPTIONS

- Remote Touch screen controller
- BACnet remote control
- WiFi connectivity
- Painted aluminum enclosure
- OEM kit options



**ACA** dry fog atomizer are supplied with water and compressed air. Atomizer's **patented** acceleration chamber creates an airflow pattern reaching supersonic speeds. The airflow sucks in water from a venturi column. The impact between the supersonic flow of air and the water generates shock waves, which produce the micro-droplets. The "solid con" jet of micro droplets forms a uniform "dry fog" which evaporates quickly into the air.

This atomizer producing a **very fine mist** (2 to 4 $\mu$ m) is the ideal humidification solution for **cold storage** as droplets are not freezing up even at very low temperature such as 0°C.

**ACA** atomizer is robust and can accept untreated water up to 100ppm TDS or RO treated water.

- Dry fog producing 2 to 4 $\mu$ m water droplets.
- Low energy consumption.
- Capacity from 6 to 472kg/h.
- Low compressed air pressure required (600kPa).
- Original patented venturi atomizer.
- Atomizer with non clogging large orifice & maintenance free.
- Accepts untreated water.
- Operate at very low temperature .
- High accuracy +/-1%RH. & high humidity: up to 96%RH.
- Electronic Controller handling 1 or 2 zones or more.

### DIRECT IN SPACE ATOMIZING

In direct in-room configuration the **ACA** humidifiers consists of the following components:

- Atomizing box with 2 or 4 atomizers easy to install on the wall,
- Electronic controller,
- RH% & temperature sensors,

Direct in-room atomizing is ideal for printing woodworking shop or for cold storage.

### IN DUCT ATOMIZING

For In-duct configuration the **ACA** atomizer will be pre-installed on ramps at the factory.

- Atomizing ramps, grid and support are made up to the dimension of the duct,
- Droplet separator will be provided.
- A wet duct section should be provided (by others)

In duct atomizing is used for data center, server room .

### INNOVATION

**ACA** Atomizer's patented venturi design makes it the most robust atomizer on the market, with no moving part or internal spring and a large orifice allowing for:

- No clogging
- Maintenance free
- Use of untreated water ( up to 100ppm TDS ).



**Most robust and durable atomizer of the industry.**



**Best warranty of the industry!**

*If your humidifier installation has been verified and validated (with a start-up report) by one of our authorized representatives.*

## TECHNICAL DATA

Model	ACA-S2	ACA-S4	ACA-S6	ACA-Dx
<b>Capacity</b> (kg/h)	12.0	24.0	36.0	6.0 to 472.0
<b>Air pressure</b>	600 to 800	600 to 800	600 to 800	600 to 800
<b>Air consumption</b> (l/min)	120 @ 600kPa	240 @ 600kPa	360 @ 600kPa	120 @ 600kPa per atomizer
<b>Water pressure</b> (kPa)	275 to 415	275 to 415	275 to 415	275 to 415
<b>Total Dissolved Solids</b> (ppm)	100ppm max	100ppm max	100ppm max	100ppm max
<b>Voltage</b> (Vac)	100 to 250Vac	100 to 250Vac	100 to 250Vac	100 to 250Vac
<b>Power</b> (W)	15	15	15	15 to 200

## TECHNICAL DRAWINGS

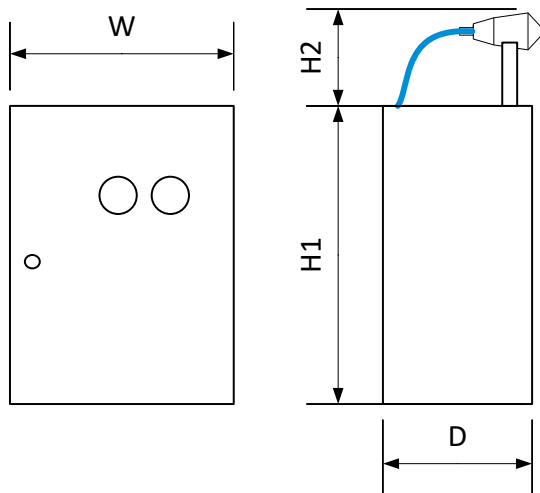

Model	Dimensions (cm)				Net Weight
	W	H1	H2	D	
<b>ACA-S2</b>	40.0	50.0	10.0	20.0	11kg
<b>ACA-S4</b>	40.0	50.0	10.0	20.0	12kg
<b>ACA-S6</b>	40.0	50.0	10.0	20.0	13kg

## NOMENCLATURE

Model	Designation
<b>ACA-S2</b>	ACA in space 2 nozzles
<b>ACA-S4</b>	ACA in space 4 nozzles
<b>ACA-S6</b>	ACA in space 6 nozzles
<b>ACA-Dx</b>	ACA Duct distribution (1 to 80 nozzles)
<b>ACA-NOZZ6</b>	Nozzle only
<b>ACA-OCUx</b>	Control panel (X = 1 or 2 zones)

### COMPONENTS SUPPLIED

- Electronic controller for 1 or 2 zones control
- RH% & Temperature sensor.
- Power supply (100 to 250Vac, 1ph, 50/60Hz)
- 2 stages water filters 1µm & anti-bacterial silver ions cartridge
- Water & air hoses

### LIST OF OPTIONS

- Modbus remote communication
- BACnet remote control.
- Stainless steel enclosure

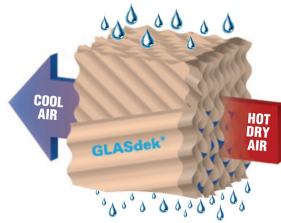

**AEM** evaporative humidifier and cooler using evaporative media is designed to be installed in Air Handling Unit (AHU) or ventilation duct. Water is circulated in the evaporative media, as hot air is passing through the wet media, water is evaporated by the latent energy of the air. As a result the air gets cooled off up to 12°C and humidified at the same time.

**AEM** evaporative humidifier by **steamOvap®** is redefining adiabatic humidification. It is intrinsically safe regarding the risk of bacteria growth (such as legionella), since it is not re-circulating any water, and at no time would cause stagnant water in internal circuit or surrounding. It is also the humidifier that consumes the least electricity in the industry with only 30W whatever its capacity.

**AEM** is aerosol free and can operate with city drinking water or reverse osmosis water.

**AEM** evaporative humidifier is ideal when warm and dry air is entering or returning HVAC system - i.e. in data center, when you can fully benefit from the adiabatic process cooling and humidifying the air at the same time.

- Up to 99% efficiency (at 1.0m/s)
- Intrinsically safe regarding the risk of bacteria growth.
- Very low energy consumption, & pressure drop (less than 50W & 75Pa) .
- Inorganic ceramic evaporative media material.
- Suitable for tap or RO water without additional option.
- Innovative pulse to demand control minimal water loss.
- GLASdek® evaporative media by Munters, UL900 Class1 & GREENGUARD Gold Certified by UL
- Integral stainless steel construction.

### BEST IN-DUCT SOLUTION

- Why spraying in a duct?  
If it is resulting in the need for a droplet eliminator, long absorption distance, risk of water aerosol in the air and the need for pure water, all this at more cost !
- Unlike any other adiabatic humidifier on the market:
  - **AEM** is not recirculating water !  
So there is absolutely no stagnant water and no bacterial risk associated.
  - **AEM** does not need pure water to operate! It can operate with **tap water** with no dust or residue in the air.
  - **AEM** provides the lowest pressure drop of the industry, and does not require "wet" duct section !
  - **AEM** uses less than 50W of power to operate.

### INNOVATION

- Unique pulse to demand water flow, ensures:
  - No stagnant water.
  - No water loss.
  - Accurate & modulating control.
  - No unsafe live electrical submerged or closed to water.
- 7in touch screen user interface.

### MADE IN CANADA

Proudly designed and made in Canada by a dedicated team combining more than 40 years of experience in humidification.



### Best warranty of the industry!

If your humidifier installation has been verified and validated (with a start-up report) by one of our authorized representatives.

# TECHNICAL DATA

Model	AEM100	AEM150	AEM200	AEM300	AEM450
<b>Evaporation efficiency</b>	62% @ 1.0m/s	76% @ 1.0m/s	85% @ 1.0m/s	92% @ 1.0m/s	99% @ 1.0m/s
<b>Capacity (kg/h)</b>	4 to 2200	4 to 2200	4 to 3200	4 to 4500	4 to 4500
<b>Pressure Drop</b>	Below 5Pa at 1.0m/s	Below 5Pa at 1.0m/s	Below 5Pa at 1.0m/s	Below 10Pa at 1.0m/s	Below 10Pa at 1.0m/s
<b>Water TDS (ppm)</b>	30 to 1,000ppm	30 to 1,000ppm	30 to 1,000ppm	30 to 1,000ppm	30 to 1,000ppm
<b>Power supply (Vac &amp; W)</b>	120 Vac, 1ph 30W	120 Vac, 1ph 30W	120 Vac, 1ph 30W	120 Vac, 1ph 30W	120 Vac, 1ph 30W

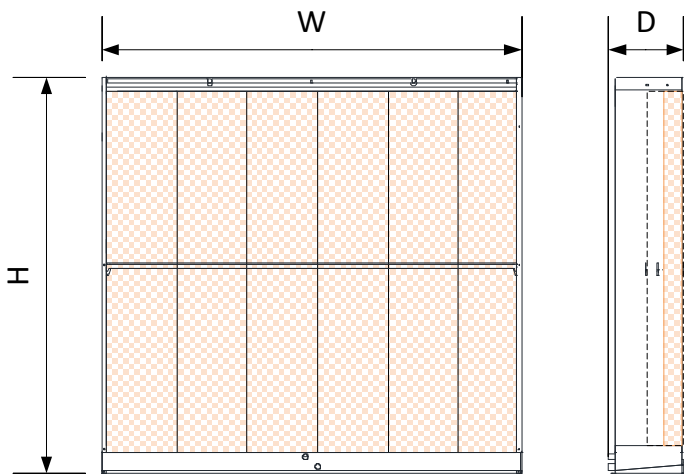

Model	Dimensions		
	W	H	D
AEM100	Duct Width - 10cm	Duct Height - 10cm	60cm Max.
AEM150			
AEM200	Min=60cm Max=180cm	Min=60cm Max=300cm	
AEM300			
AEM450			

Evaporation efficiency

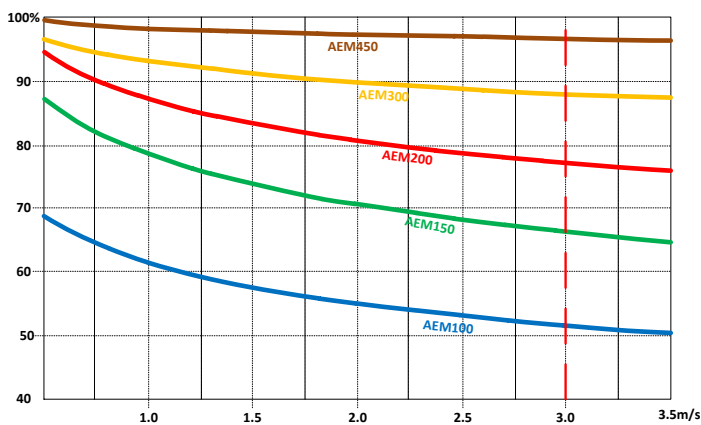

Pressure drop

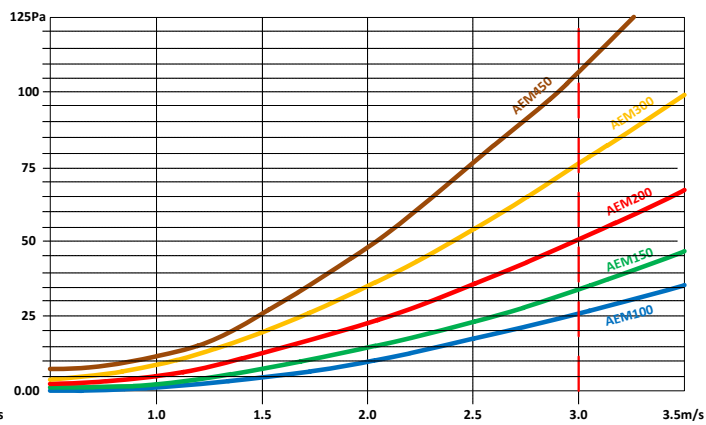

Note: Installation of droplet separator is required when air velocity is above 3.0m/s

## NOMENCLATURE

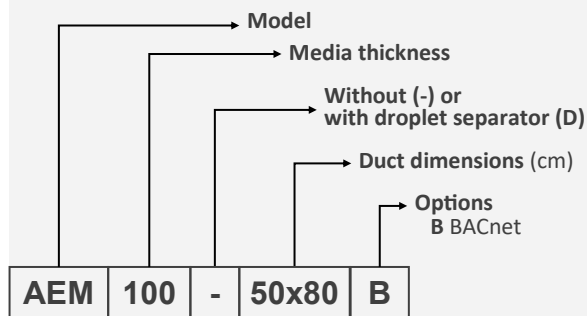

## COMPONENTS SUPPLIED

- Electronic controller with 7in touch screen.
- 2 stage water filters 1µm + anti-bacterial silver ions cartridge
- Electric water valve(s) (24vac)
- Water hoses
- 230Vac, 1ph power supply

# SAFETY CONTROLS

## DHL

### DUCT HI-LIMIT HUMIDISTAT

**DHL** is used as High limit humidistat safety when humidifying in duct. It is suitable for steam or adiabatic humidification.

**Control mode:**  
ON/OFF

**Set point range:**  
15 to 95%RH

**Long term stability:**  
+/-1.5%RH

**Contacts type & rating:**  
NO & NC SPDT potential free contacts  
maximum 5A at 24Vac or Vdc

**Switching differential:**  
4%RH



## DAP

### DUCT AIR PROVING SWITCH

**DAP** is used as Air proving safety switch when humidifying in duct. It will prevent from operating humidifier in case there is no air flow.

**Control mode:**  
ON/OFF

**Set point range:**  
20 to 300Pa

**Max pressure:**  
7500Pa

**Contacts type & rating:**  
NO & NC SPDT potential free contacts  
maximum 2A at 250Vac  
or 1A at 30Vdc

**Max Switching frequency:**  
6 cycles / min



## FLS

### FLOOR LEAK SWITCH

**FLS** is used to detect any water accumulation on the floor of a room or duct, it is used to prevent from any water damage.

**Supply voltage:**  
11 to 27Vac or Vdc

**Relay:**  
SPDT

**Relay rating:**  
1A @ 24Vac/Vdc

**Display:**  
Green LED = Power On  
Red LED = Alarm

**Probes**  
Gold plated 38mm adjustable

**Housing:**  
Cast aluminum, Stainless steel cover



# RH% SENSORS & CONTROLLER

## DHS

### DUCT RH% SENSOR

**DHS** is used as RH% sensor when humidifying in duct. It is suitable for steam or adiabatic humidification. It should be installed in returned air duct for best reading.

**Range:**  
0-100%RH

**Output:**  
standard 0-10Vdc  
optional 4-20mA (suffix 420)

**Supply voltage:**  
15 to 28Vac or 15 to 36Vdc

**Accuracy:**  
 $\leq \pm 3\%$  RH (at 25°C, 20 to 80%RH)  
optional  $\leq \pm 2\%$  RH

**Hysteresis:**  $\leq \pm 1\%$  RH

**Response time:**  $\leq 10$ s (25°C)

**Drift:**  $\leq \pm 0.5\%$  RH



**Options:**  
LCD display  
Additional SPDT relays

## RHS

### ROOM RH% SENSOR

**RHS** is used as room RH% sensor. It is suitable for steam or adiabatic humidification.

**Range:**  
0-100%RH

**Output:**  
standard 0-10Vdc  
optional 4-20mA (suffix 420)

**Supply voltage:**  
15 to 28Vac or 15 to 36Vdc

**Accuracy:**  
 $\leq \pm 3\%$  RH (at 25°C, 20 to 80%RH)  
optional  $\leq \pm 2\%$  RH

**Hysteresis:**  $\leq \pm 1\%$  RH

**Response time:**  $\leq 10$ s (25°C)

**Drift:**  $\leq \pm 0.5\%$  RH



**Options:**  
LCD display  
Additional SPDT relays

## RHC

### ROOM RH% CONTROLLER

**RHC** is used as room RH% sensor. It is suitable for steam or adiabatic humidification.

**Range:**  
0-95%RH,

**Humidification set point range:**  
10% RH to 90% RH

**Supply voltage:**  
19 to 30Vac

**Accuracy:**  
 $\pm 5\%$  RH (at 10 to 32°C, 20 to 95%RH)



**Options:**  
BACnet MS/TP

# WATER FILTER & CONDITIONERS

## WF-105

### 2 STAGE WATER FILTERS 10 + 5 MICRONS

**WF-105** is recommended to be installed on the city water supply line to any steam humidifiers, such as **IER** or **ISE**.

**2 stage filtration:**

- **1st stage:** 10 µm sediment
- **2nd stage:** 5 µm PP

**Cartridges size:** 25mm

**Inlet & outlet diam.:**  
BSP 1/2

**Max pressure:**  
1400kPa

**Max Flow:** 266l/min



## WF-1S

### 2 STAGE WATER FILTERS 1 MICRON + SILVER IONS

**WF-1S** is included with **AEM** or **ACA** humidifier, it is a basic water filtration for any adiabatic humidifier preventing foreign particle and disinfecting incoming water.

**2 stage filtration:**

- **1st stage:** 1 µm PP
- **2nd stage:** antibacterial, silver ions cartridge

**Cartridges size:** 25mm

**Inlet & outlet diam.:**  
BSP 1/2

**Max pressure:**  
1400kPa

**Max Flow:** 266l/min



## WS-MG

### WATER CONDITIONER CATALYTIC

**WS-MG** is a 3 stage water filters and conditioner to avoid large scale accumulation when steam humidifiers such as **IER** or **ISE** are supplied with hard water.

It is a good alternative to ions exchange water softener replacing calcium and magnesium by sodium making boiling water prone to foam, resulting is big waste of water and energy due to frequent or constant drain.

**3 stage filtration:**

- **1st stage:** 10 µm sediment
- **2nd stage:** Carbon filter
- **3rd stage:** hard water conditioner

**Cartridges size:** 25mm

**Inlet diam.:** BSP 1/2

**Outlet diam.:** 9.5mm compression

**Max pressure:**  
700kPa

**Max Flow:**  
2.7l/min





# WRO

## REVERSE OSMOSIS WATER FILTRATION STATION

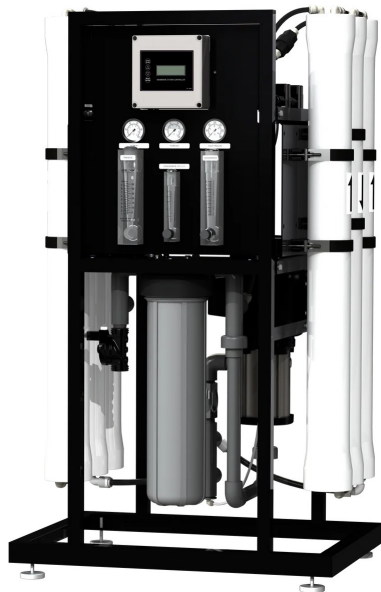

WRO2000 to 8000



Buffer tank



WRO750 & 1500

WRO Series commercial reverse osmosis station deliver on performance, quality and effectiveness. These RO stations come equipped with many standard features, including: extra low energy and high rejection membranes, 300 PSI rated fibreglass membrane housings for increased durability, 5-micron sediment and carbon pre-filter, flow meters and pressure gauges. Our advanced WRO controller delivers all the standard operational requirements. Its easy to-read screen and alarms make it ideal for improved notifications and monitoring, it is including the following features: Permeate TDS monitoring and alarm, Low-pressure monitoring and alarm, Run-time monitor and pre-treatment lock out, Low-pressure switch with auto restart, High-pressure switch for pressurized tanks, Optional permeate flush for extended RO membrane life, Optional wiring for tank level control input for float switch

### TECHNICAL DATA

		Model	WRO100	WRO200	WRO350	WRO750	WRO1500	WRO2000	WRO4000	WRO6000	WRO8000
Design	Config.	Single pass	Single pass	Single pass	Single pass	Single pass	Single pass	Single pass	Single pass	Single pass	Single pass
	Feedwater max TDS	2,000ppm	2,000ppm	2,000ppm	1,000ppm	1,000ppm	2,000ppm	2,000ppm	2,000ppm	2,000ppm	2,000ppm
	Standard recovery	35%	38%	40%	38%	65%	32%	48%	52%	65%	
Flow rates l/h	Permeate Pure water	15.8	31.6	54.7	118.5	237.1	316.9	633.8	948.4	1267.7	
	Min. Concentrate	57.0	95.0	95.0	378.0	378.0	682.0	682.0	682.0	682.0	
RO membrane	Qty	1	2	1	1	1	1	2	3	4	
	Size	B401	B401	3012	3018	3018	4040	4040	4040	4040	
	Nom. TDS reject	95%	95%	98%	98%	98%	98.5%	98.5%	98.5%	98.5%	
Pump	Pump type	None	None	None	Rotary vane	Rotary vane	Multi-stage	Multi-stage	Multi-stage	Multi-stage	
	Motor HP	/	/	/	1/3	1/2	1.5	1.5	2	2	
	RPM	/	/	/	1725	1725	3480	3480	3480	3480	
Volt., Ph, Current		/	/	/	230Vac, 1ph 3.4A	230Vac, 1ph 4.3A	230Vac, 1ph 8.5A	230Vac, 1ph 8.5A	230Vac, 1ph 11.0A	230Vac, 1ph 11.0A	
Overall dimensions WxDxH (cm)		45x30x82	45x30x82	30x43x81	43x33x86	43x33x86	63x41x140	63x41x140	81x61x140	81x61x140	

All of the WRO station models are including a buffer tank or clean water storage tank & water delivery pump.

# INDOOR AIR HUMIDIFICATION AND HUMAN HEALTH

Maintaining relative humidity (RH) between 40% and 60% offers many health benefits including: reduced virus transmission, virus deactivation, improved respiratory immune function, improved general health, skin and eye hydration, minimised allergy and asthma effects, reduced allergen development, protection from airborne chemicals.

Maintaining this optimum RH range creates a healthier indoor environment, potentially reducing sick days and improving overall wellbeing.

This article is supported by numerous scientific studies and recommendations from AHRI and ASHRAE, please visit our dedicated webpage to learn more about the benefits of maintaining 40-60% RH in your indoor environment.



Compendium

## THE STERLING CHART

The Sterling Chart has been originally published in a scientific research paper from 1986. Title of this article is "Indirect Health Effects of Relative Humidity in Indoor Environments" by Anthony V. Arundel, Elia M. Sterling, Judith H. Biggin, and Theodor D. Sterling.

Here is an abstract from the conclusion of this determining study: "This review of the indirect health effects of relative humidity indicates that adverse health effects would be minimized by **maintaining relative humidity between 40 and 60%**. Presently indoor relative humidity levels below 40% are widespread in winter. An increase in low relative humidities to above 40% should reduce the incidence of respiratory infections, the severity of allergic and asthmatic reactions, and indoor ozone levels."

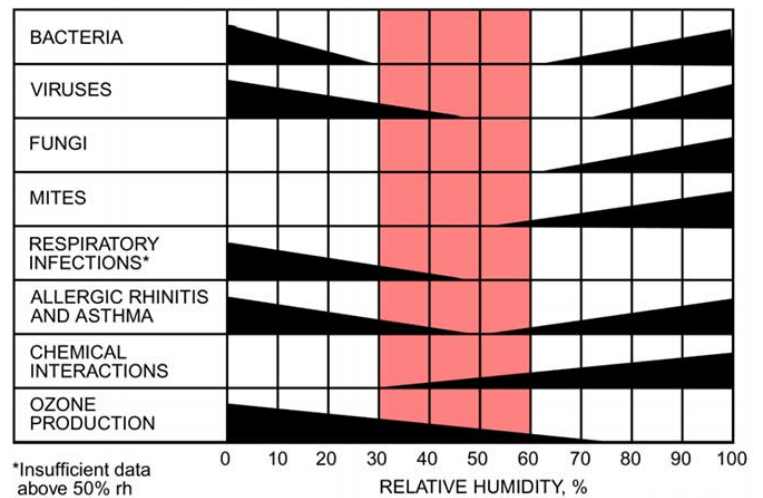

The Sterling Chart from 2016 ASHRAE Handbook HVAC System and Equipment, Chapter 22.

Since its first publication many other scientific studies have confirmed validity and importance of this study and of the Sterling chart; ASHRAE ( American Society of Heating, Refrigerating and Air-Conditioning Engineers) as adopted this chart and it is now part of its Handbook.

## PROPER WATER CONTENT IN AIR IS CRITICAL

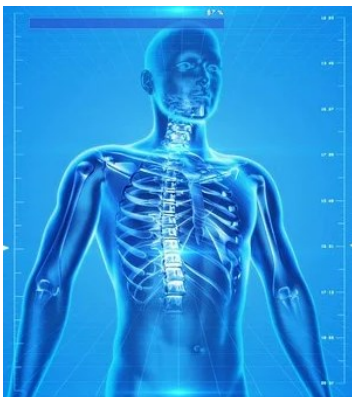

The human body is made up of over 65% water!

This is why we are susceptible to dehydration, of course the easiest way to hydrate our body is to drink water. But if we find ourselves in a very dry environment, our body will tend to dehydrate more quickly and all the surfaces of our body in contact with this very dry environment will dehydrate and become more vulnerable.

The prevention of dehydration is critically important. Many human mechanisms exist to maintain overall fluid balance. When dehydration of our body occurs we will start to feel discomfort, this discomfort is the first signal that our health will be impacted.

When the surrounding air is dry (a humidity level of 40% or less) our body's fluid balance is attacked. it is a physical phenomenon observed on all materials and living beings: a transfer of humidity always takes place between a dry atmosphere and any element or beings that is in this environment. Element with higher water content will transfer part of it to the drier atmosphere in order to achieve a balance of the water content of the two elements that are in contact.

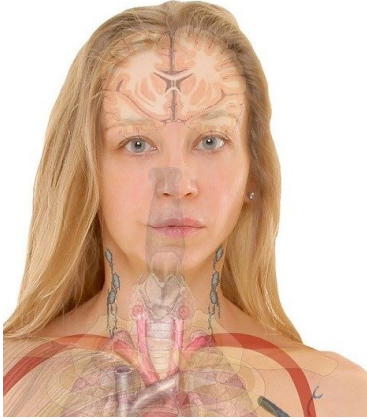

One of the first external signs of a lack of humidity in a building is the appearance of static electricity. It is manifested by electric shocks when approaching switches or electrical and electronic products such as computers or televisions. Although in everyday life these electric shocks are unpleasant but not dangerous for humans, electronic devices can be affected and damaged by such shocks.

Another of the first direct effect of the lack of humidity in a building is having dry skin. The skin is our body's first barrier to the outside world. Skin does protects us from multiple micro aggressions every day without our being aware of it. As soon as our skin is drying up we become more sensitive to micro cuts, the skin could itch, redness can also appear and small cracking will appear. Skin conditions such as psoriasis may become aggravated at lower relative humidity.

The tear film that protects our eyes is also very sensitive to ambient humidity. Low humidity causes a breakdown of the tear film; our eyes become vulnerable to external contaminants, such as dust or viruses, they will become dry and itchy.

The respiratory tract is the other part of our body that is directly affected by low humidity. It is composed of the nasal passages, the throat, the trachea, the lungs.

Membranes in the nose dry out quicker in low humidity, as humidity above 30% RH is needed for the mucous membranes in the nose to properly filter the air we breathe. We have observed more significant impact on the elderly or on people suffering from others health conditions.

At low humidity level we will observe dryness of throat, this will cause increased hoarseness or laryngitis.

Low humidity results in breathing smaller particles through our lungs. It will increase creation of smaller exhaled breathe aerosols that can retransmit microbes and viruses and greater likelihood of particles being inhaled deeply.

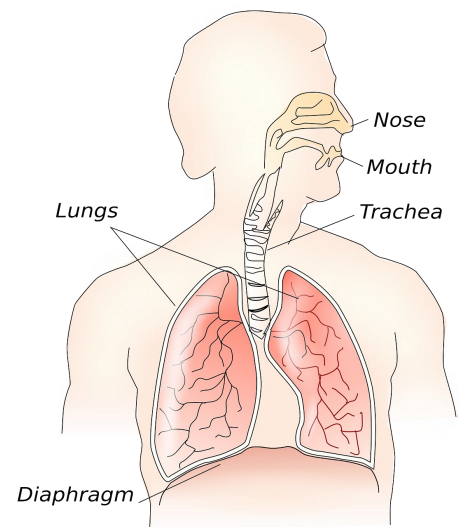

## HOW A PROPER RH% CAN HELP FIGHT VIRUSES ?

John Noti, & al, in a research paper published in 2013, has demonstrated that "Humidity Leads to Loss of Infectious Influenza Virus from Simulated Coughs".

This study has since been verified and confirmed by other researches and with other respiratory viruses such as SARS CoV-1 and CoV-2 more recently.

The infectivity and survival rates of respiratory viruses are greatly reduced when relative humidity is between 40 and 60%.

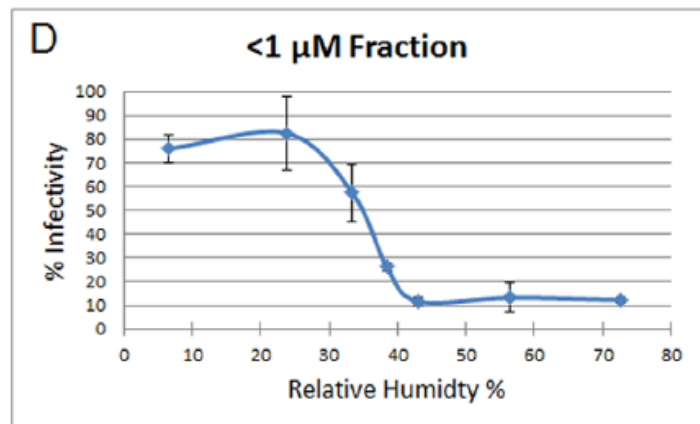

This article is based on a compendium of scientific research and on the common and accepted knowledge recognised by AHRI (Air-conditioning Heating and Refrigeration Institute) and ASHRAE (American Society of Heating, Refrigerating and Air-Conditioning Engineers). You can find their recommendations on their respective websites. A list of most of the relevant scientific research on the effects on human health of controlled humidity levels between 40 and 60%RH in buildings and homes is also available on our website: <https://steamovap.com/solutions/compendium-of-scientific-studies/>

# RECOMMENDED AIR CONDITIONS BY APPLICATION

	Process or areas	Temperature	Humidity level (RH%)	Recommended humidifier
People	Home / Residence	21-23°C	30-40%	IER electric steam
	Office / Commercial buildings	21-23°C	30-40%	IER electric steam
	Hotel	21-23°C	30-40%	IER electric steam
	School	21-23°C	30-40%	IER electric steam
	Hospitals & Health Care	22-24°C	40-60%	IER, ISE or ILS steam
	Nursing home	21-23°C	50-60%	IER, ISE or ILS steam
	General clinical areas	21-22°C	40-60%	IER, ISE or ILS steam
	Surgical areas	20-24°C	50-60%	IER or ISE steam
	Obstetrical areas	24-27°C	40-60%	IER or ISE steam
Well-ness	Hamмам	40-50°C	100%	IER electric steam
	Spa	22-24°C	30-60%	IER electric steam
	Hot Yoga	40°C	40-60%	IER electric steam
Art	Concert hall	20-22°C	45-60%	ISE or ILS steam AEM evaporation
	Art conservation	17-22°C	45-55%	IER, ISE or ILS steam
	Stuffed fur animals & Fur garment storage	4-10°C	55-65%	IER, ISE or ILS steam
Agri-food industry	Meat conservation	0-1°C	90-95%	ACA atomizing or AUL ultrasonic
	Fruit Cold storage	4-7°C	95%	ACA atomizing or AUL ultrasonic
	Egg hatchery	37-39°C	>60%	IER or ILS steam
	<b>Mushrooms</b>			AUL, ACA or AEM absorption
	Spawn added	16-22°C	>95%	AUL, ACA or AEM absorption
	Growing period	10-16°C	80-85%	AUL, ACA or AEM absorption
	Storage	0-2°C	80-85%	AUL, ACA or AEM absorption
	<b>Tea packaging</b>	17-20°C	60-70%	ACA atomizing
	<b>Cereal packaging</b>	24-27°C	45-50%	ILS steam or ACA atomizing
	<b>Wine making &amp; distillery / ageing</b>	10-16°C	90-95%	AUL ultrasonic or ACA atomizing
	<b>Bread proofing</b>	27-32°C	>80%	IER or ILS steam
Tobacco	Cigar & cigarette making	21-24°C	55-65%	IER or ILS steam
	Softening	29-32°C	85-88%	IER or ILS steam
	Stemming & stripping	24-29°C	70-75%	IER or ILS steam
	Filler tobacco conditioning	21-24°C	75-80%	IER or ILS steam
	Wrapper tobacco conditioning & storage	24-29°C	75-80%	IER or ILS steam
In-door growing	Cloning	23-25°C	70-80%	IER steam or AUL or ACA
	Seeding	26°C	65-70%	IER steam or AUL or ACA
	Vegetative growth	21-29°C	40-70%	IER steam or AUL or ACA
	Flowering	20-25°C	30-50%	IER steam or AUL or ACA
	Drying	18-24°C	40-50%	IER electric steam
Industry	<b>Data centers &amp; Server rooms</b>	15-32°C	20-80%	AUL or AEM evaporative
	<b>Electronics production</b>	21-24°C	40-50%	IER, ILS, AUL or AEM
	<b>Laboratories &amp; Clean rooms</b>	22-23°C	42-48%	IER or ILS steam
	<b>Static Electricity Control</b>	-	>55%	IER, ILS, AUL, ACA or AEM
	<b>Packaging</b>	20-22°C	40-45%	AUL, ACA or AEM absorption
	<b>Painting</b>	16-32°C	50-80%	IER, ILS or AEM
	<b>Printing</b>	24-27°C	45-50%	IER steam, AUL or ACA atomizing
	<b>Textile</b>	24-27°C	>55%	ACA atomizing
	<b>Woodworking (general)</b>	24-27°C	>55%	ACA atomizing
	<b>Plywood hot pressing</b>	32°C	60%	IER or ILS steam
	<b>Photographic Processing</b>	22-23°C	40-50%	IER or ILS steam
	<b>Plastic cellophane wrapping</b>	24-27°C	45-65%	IER or ILS steam
	<b>Paper processing / finishing</b>	21-24°C	40-45%	IER steam or AUL or ACA atomizing
	<b>Optical lenses fusing</b>	23-24°C	40-50%	IER or ILS steam
	<b>Optical lenses grinding</b>	26-27°C	75-85%	IER or ILS steam
Pharmaceutical	Colloids	24°C	30-50%	IER, ISE or ILS steam
	Cough drops	24°C	40%	IER, ISE or ILS steam
	Ampoule manufacturing	24°C	35-50%	IER, ISE or ILS steam
	Microanalysis	24°C	50%	IER, ISE or ILS steam
	Serums	24°C	50%	IER, ISE or ILS steam
	Animal rooms	24-27°C	50%	IER, ISE or ILS steam

# USEFUL FORMULAS & CONVERSIONS

Qty of power to produce steam	625W are required to bring 1 liter of water to steam (at sea level)	
Current calculation	1 phase: $I(A) = \text{Power}(W) / \text{Voltage}(V)$	
	3 phases: $I(A) = \text{Power}(W) / \text{Voltage}(V) \times 1.732$	
Power conversion	1kW = 3412Btu	1,000Btu = 292.9W
Air flow conversion	1m <sup>3</sup> /sec = 0.58857CFM	1CFM = 1.699 m <sup>3</sup> /sec
Air velocity conversion	1l/sec = 2.12FPM	1FPM = 0.47l/sec
Pressure conversion	1kPa = 0.145PSI	
	1Pa = 0.004in w.c.	
Temperature conversion	$C = (F - 32) / 1.8$	
	$F = (C \times 1.8) + 32$	
Weight conversion	1kg = 2.2lb	1lb = 0.45kg

## CROSS REFERENCE TABLE

Other make				steamOvap	Comments
CONDAIR	DRISTEEM	CAREL	DEVATEC/ ARMSTRONG		
Humilife or CP3 electrode boiler	/	CompactSteam electrode boiler	none	<b>RES</b> electric resistive	Resistive type is superior to electrode boiler: better control and no plastic waste.
EL series electrode boiler	XT electrode boiler	HumiSteam electrode boiler	ELMC or EHU electrode boiler		
RS series resistive heater	RTS resistive heater	HeaterSteam resistive heater	RTH or HC6000 resistive heater	<b>IER</b> electric resistive	Serviceability and cost of operation do matter.
SE series steam exchange	STS steam exchange	none	CS series steam to steam	<b>ISE</b> steam exchange	ISE is the only one that can be cleaned with no use of tool in a few minutes.
LS series live steam	Mini bank, single or multiple tube steam injection	none	Armstrong serie 1000 & 9000	<b>ILS-P</b> live steam	Jacketed live steam. Still a valid method of steam humidification in 2024.
SAMe pressurized steam	Ultrasorb MP, LV, LH or XV pressurized steam	Centralised steam distributors	Humidipack	<b>ILS-SO or ILS-SE</b> live steam	steamOvap® is offering all possible configurations.
US Series	Adiatec Mode BR or BA	HumiSonic ultrasonic	None	<b>AUL</b> ultrasonic	AUL2 is modular and most compact
AF22, AF series or, Draabe series compressed air, HP series or ML series	Adiatec high pressure system	Mc Multizone compressed air HumiFog high pressure	CoolFog compressed air	<b>ACA</b> atomizing	Water droplet size does matter: (droplets from high pressure atomizers are 10 times bigger than ACA).
ME series or DL series hybrid evaporative	Wetted media system	none	EvaPack	<b>AEM</b> evaporative	Hygiene control is critical. AEM is hygienically safe by design

# WARRANTY & RETURN POLICY

**RETURN POLICY** - A Return Material Authorization (“RMA”) is required prior to returning products for any reason. No merchandise shall be returned without a written authorization from **steamOvap**, in its sole discretion may reject any non-warranty return request. Non-warranty returns of unused and resalable products for credit will be subject to **steamOvap’s** return policies in effect at the time, including applicable restocking charges and other conditions of return. Return requests of incorrectly ordered items will only be accepted against a restocking charge of 10% within ninety (90) days after delivery. Products returned must be properly packed and shipped to **steamOvap** specified locations. All shipping containers must be clearly marked per **steamOvap’s** instruction. Buyer will be responsible for all costs and expenses associated with any returns of products (other than products returned at **steamOvap’s** request pursuant to Limited Warranty here below) and will bear the risk of loss or damage of all returned products, unless **steamOvap** agrees otherwise in writing. **steamOvap**, in its sole discretion may reject any return of product not approved by **steamOvap** in accordance with this paragraph or otherwise not returned in accordance with **steamOvap’s** then current return policies.

**LIMITED WARRANTY** – **steamOvap** warrants that the products sold hereunder will be free from any defects in parts and workmanship for a period of three (3) years after start-up, except for ACA atomizers that are granted a life time warranty (15 years), provided that a start-up report with no installation non-conformance has been done and signed by the authorized **steamOvap** local representative. Otherwise the warranty period is reduced to eighteen (18) months from date of shipment. **steamOvap’s** obligations and liabilities under this warranty are limited to supply replacement parts or replace the products free or charge, or at **steamOvap’s** sole discretion refund Buyer the price of the products (or a proportionate part thereto), providing that the defective part(s) or product is returned in accordance with **steamOvap’s** return policy section.

Parts used for repairs are warranted for the balance of the term of the warranty on the original product or ninety (90) days, whichever is longer.

Visit our website : [steamovap.com](http://steamovap.com) for more information.

## CONTACT INFO

### steamOvap

1490 Mazurette  
Montreal, Quebec, H4N 1H2, Canada

[info@steamovap.com](mailto:info@steamovap.com)

Quick access  
to website



## CUSTOMER SERVICE

**+1-514-357-4477**

## WEBSITE

<https://steamovap.com>

## SOCIAL NETWORK

Follow us on  & 

## INTERNATIONAL REPRESENTATION

Consult the page “steamOvap around the world ” on our website to find the latest list of representatives, or contact us at [info@steamovap.com](mailto:info@steamovap.com)

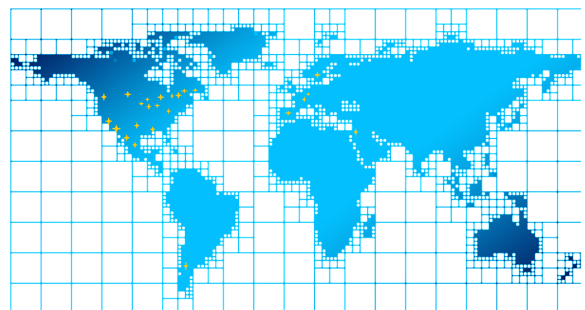





**steamOvap technologies inc.**

**E\_mail:** [info@steamovap.com](mailto:info@steamovap.com)

**Tel:**+1 514 357 4477

**Address:** 1490 Mazurette, Montreal, Qc, H4N 1H2, Canada

**Web:** <https://steamovap.com>

© 2025 [SI Units]