

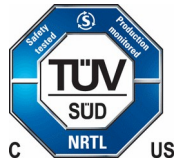

**RES**

## STEAMORES ELECTRIC STEAM HUMIDIFIER



## Installation and Operation Manual

**Please read and save this manual**

# Introduction

## Foreword

Thank you for purchasing RES electric steam Humidifier.

If you have questions or comments please contact us:

[www.steamOvap.com](http://www.steamOvap.com)

[info@steamOvap.com](mailto:info@steamOvap.com)

1-844-357-4477

## Intended use

**RES** electric steam humidifier is intended exclusively to produce steam from water at atmospheric pressure for air humidification.

Operating conditions are specified in this Installation and Operation Manual (IOM).

Operation of this humidifier in the intended use scope requires that all directions and information contained in this IOM are observed.

Any other use or operation outside the above design scope without written authorization from steamOvap may lead to trouble and hazardous conditions and will void warranty.

No alteration or modification to the humidifier must be done without written authorization from steamOvap.

Replacement of any defective components must be done with original component and spare parts from steamOvap representative.

## Installation and Operation Manual Limitation

This IOM is intended for trained and qualified personnel and must be applied along with the applicable local codes and regulations.

Any work related to installation or service for this humidifier must comply with local code and regulation regarding safety and prevention of accidents.

## End of life disposition

Ensure that **RES** electric steam humidifier is empty from water, if not proceed same way as for a standard drain for service.

Disconnect **RES** electric steam humidifier from power supply, electrical control signal, water main supply, Steam line, and drain. **RES** humidifier can then be removed from the wall or stand.

**RES** electric steam humidifier is an electrical equipment and as such **MUST** not be disposed of in domestic waste.

This humidifier should be returned to the closest **steamOvap** authorized representative for proper dismantling, recycling and disposition of components according to local regulations.

# Table of content

Introduction.....	2
Table of content.....	3
Safety warnings.....	4
Before to proceed to Installation.....	5
RES Overview.....	6
Installation overview.....	8
Step 1 - Positioning & Mounting.....	9
Step 2 - Water supply installation.....	11
Step 3 - Drain installation.....	12
Step 4 - Steam distribution.....	13
Step 5 - Power supply installation.....	16
Step 6 - Control installation.....	18
Verification before start-up.....	20
Configuration & Operation.....	21
Service.....	25
Warranty.....	27

# Safety warnings

## General



**Risk of electric shock.**

Disconnect power supply before installation or service.

For safety and warranty reasons, Installation and service of this humidifier should be carried out by trained and qualified personnel.

Any work related to installation and service of this humidifier must comply with local code and regulation regarding safety and prevention of accidents.

## Electrical Warning



**Risk of electric shock.**

Disconnect power supply before installation or service.

Power supply connection must be done by a trained and qualified electrician.

Any work related to power supply installation or service of this humidifier must comply with local code and regulation regarding safety and prevention of accidents.

## Water safety warning



Any work related to water supply, drain connection as well as steam lines and condensate returns lines installation or service of such for this humidifier must comply with local code and regulation regarding safety and prevention of accidents.

Water supply connection must be done by a trained and qualified plumber.

**Risk of malfunction.** Steam lines should not have any restriction or blockage that may cause a burst of pressure in the steam line.

## Others



**Risk of burnt, flooding or malfunction. Do not block steam outlet !**

**Risk of flooding.** In order to avoid any risk of flooding **steamOvap** recommends a Hi limit humidity switch installed in the air duct downstream of the steam distribution ramp.

**Risk of freezing.** Plan an anti-freeze system in case of installation in a location that would be exposed to outside conditions and susceptible of freezing.

# Before to proceed to Installation

*Please read this Installation and Operation manual before to proceed to the Installation*

## Receiving & Unpacking

1. Upon receipt verify that packaging is complete and not damaged.  
In case of damage, and/or missing boxes advise immediately the carrier by writing a note on the waybill.
2. Verify that model of the humidifier matches the purchase order and that all accessories are included.
3. Any missing item should be reported as soon as possible to **steamOvap** or its representative and within 5 business days after receipt.  
**steamOvap** will not assume any responsibility for missing item after this delay.
4. Proceed carefully to unpacking, and check that the humidifier and its accessories are not damaged. in case of damage please proceed as for point 3

## Included in standard delivery of RES electric steam humidifier

1. RES electric steam humidifier
2. Wall mounting bracket
3. Water supply hose
4. Collar(s) to secure steam hose on steam outlet of RES
5. 3 feet (0.9m) of steam flexible hose
6. This IOM

### Depending on steam distributrion kit ordered :

In Duct steam distribution

7. Steam ramp(s)
8. Air flow switch

In space steam distribution

9. Space blower distribution

## List of other accessories & options

10. RH% sensors for duct or room
11. HI Limit RH% switch
12. Water filtration kit

# RES Overview

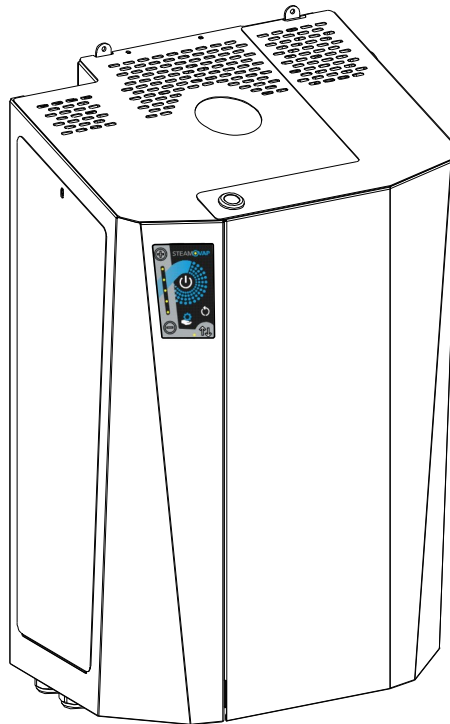

Figure 1 – RES Overview

## RES product designation & name plate



steamOvap technologies inc. Electric resistive steam humidifier			
MODEL	<b>RES120-15</b>		
S/N	YY-DDDXXX		
POWER	1.5kW	VOLTAGE	120Vac
CURRENT	12.5A	NB OF PHASE	1ph
		FREQUENCY	60Hz
		www.steamOvap.com	

Figure 2 – RES Name plate

## Model designation and options codification

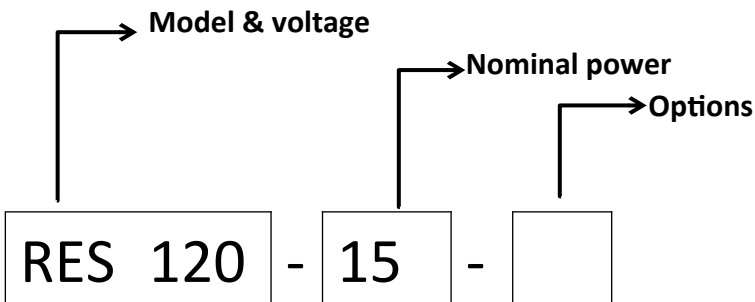

## RES electrical rating

Model	Voltage	Power	Current	Steam Capacity
RES120-06	120Vac 1ph	0.6kW	5.2A	1.9lb/h (0.86kg/h)
RES120-08		0.8kW	6.7A	2.4lb/h (1.09kg/h)
RES120-11		1.1kW	9.4A	3.4lb/h (1.5kg/h)
RES120-15		1.5kW	12.5A	4.5lb/h (2.0kg/h)
RES208-19	208Vac 1ph	1.9kW	9.1A	5.6lb/h (2.5kg/h)
RES208-24		2.4kW	11.6A	7.2lb/h (3.3kg/h)
RES208-34		3.4kW	16.3A	10.1lb/h (4.6kg/h)
RES208-45		4.5kW	21.7A	13.5lb/h (6.1kg/h)
RES240-25	240Vac/1ph	2.5kW	10.4	7.5lb/h (3.4kg/h)
RES240-32		3.2kW	13.3A	9.6lb/h (4.4kg/h)
RES240-45		4.5kW	18.8A	13.5lb/h (6.1kg/h)

## Dimensions

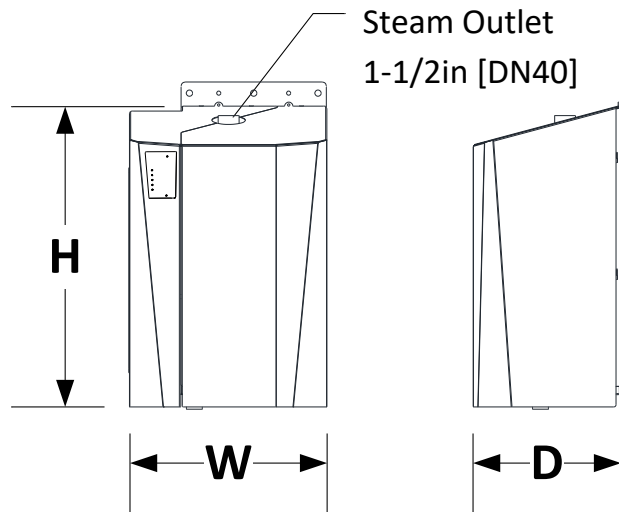

Figure 3 – RES dimensions

Model	Dimensions			Qty Steam Outlet + Ø	Net weight
	W	H	D		
RES120-06 to 15 RES208-19 to 45 RES240-25 to 45	12in (30cm)	18in (45cm)	10in (25cm)	1x 1-1/2in (x1 DN40)	22lb (10kg)

# Installation overview

## General

1. Installation of this humidifier should be carried out by trained and qualified personnel.
2. Any work related to installation of this humidifier must comply with local code and regulation regarding safety and prevention of accidents.



**WARNING. Risk of electric shock.**

Power supply must be disconnected during installation.

Main power should be connected only after all installation steps have been completed and properly verified.

## In duct typical installation

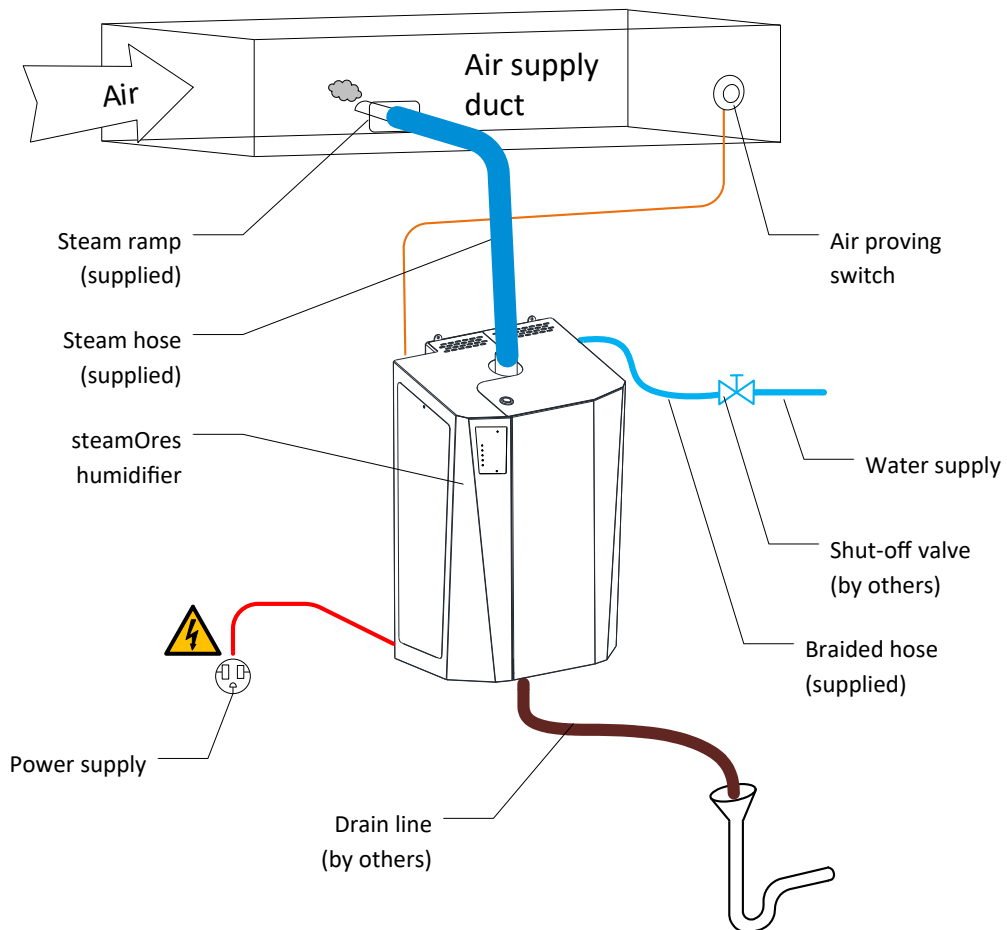

Figure 4 – installation overview with steam distribution in duct

## Installation steps :

1. Positioning & mounting of RES steam humidifier
2. Water supply installation
3. Drain installation
4. Steam line installation for duct humidification
5. Power supply installation
6. Safety & RH% control installation



# Step 1 - Positioning & Mounting

## General guidelines for positioning

RES electric steam humidifier should be positioned so that:

- Length of the steam line (or hose) is as short as possible,
- In case steam hose is used, the bend radius of 12in [300mm] is ensured
- Humidifier is easily accessible for service



**CAUTION. Risk of malfunction due to vibration. Do Not mount RES electric steam humidifier directly on ventilation duct.**

**CAUTION. Risk of flooding.** Ensure that the local where RES steam humidifier will be installed is equipped **with floor drain**.

In case of no floor drain is available; installation of a water leak detector is required in order to prevent any flooding in case of abnormal operation or service.

RES steam humidifier should be installed in a well-ventilated and dry environment.

If local is subject to below freezing point temperature, an anti freeze device (heater) installation is required.

### RES maximum ambient conditions:

Temperature: 41 to 113°F [+5 to +45°C]

Relative Humidity: 90%RH max (non condensing)

Ingress Protection for RES standard enclosure: IP30

## Clearances

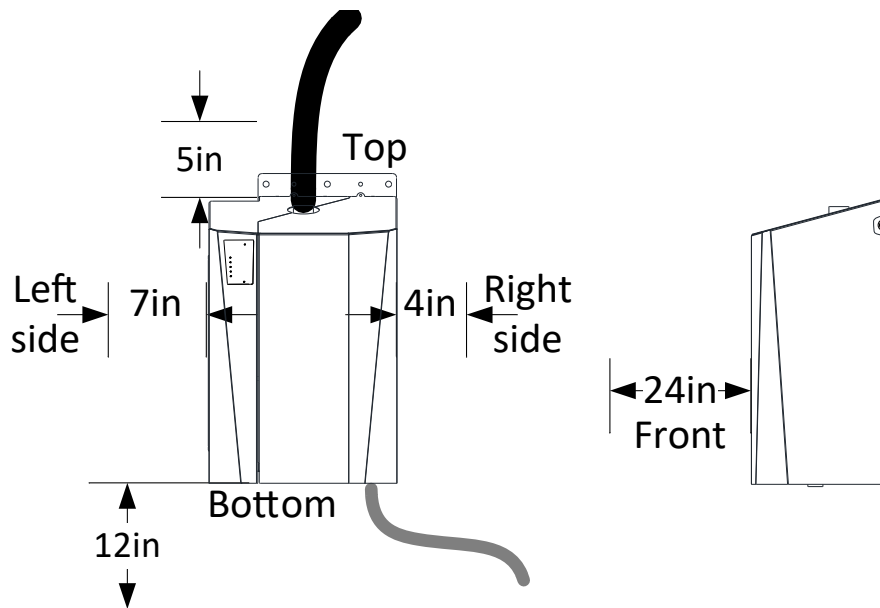

Figure 5 – minimum clearances

## Clearance guidelines

There is no minimum clearance on both side of the RES humidifier.

We recommend to maintain the following minimum clearances:

- Right hand side: 4in [10cm] to help for the supply connection
- Left hand side: 6.8in [17cm] for ease access to electrical compartment.
- In front: 24in [60cm] is required for access to the RES humidifier for service.
- Below: 12in [30cm] with floor to allow for proper drain slope and drain pipe column.
- Top: 12in [30cm] for access and proper steam connection.

## General guidelines for Mounting

**!** CAUTION. Risk of malfunction. RES steam humidifier must be levelled in X & Z axis.

### Installation on wall (with supplied mounting bracket)

1. RES is supplied with a wall mounting bracket
2. Make sure that wall structure and strength is appropriate to support the operating weight of the RES steam humidifier.
3. Mark the wall or support according to the mounting bracket holes location. Make sure that the mounting bracket is levelled. Drill holes to the wall or support.

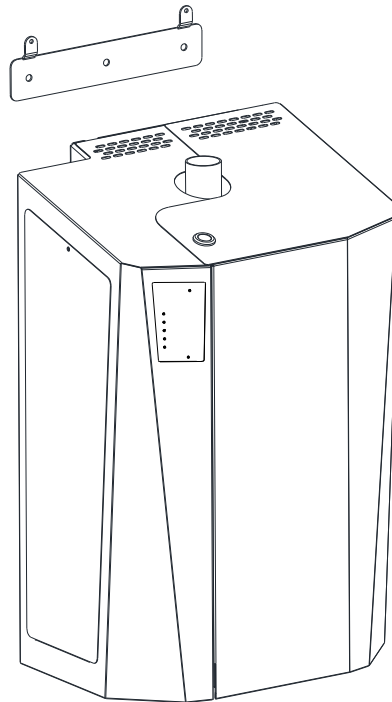

Figure 6 – Wall mounting installation

4. Use anchors of sufficient size, at least 1/4in [5mm]. Install the mounting bracket to the wall or support. Reconfirm that the mounting bracket is properly levelled.
5. Hung the RES steam humidifier onto the mounting bracket and install the 2 supplied screws holding the RES humidifier onto the mounting bracket.

RES humidifier can be installed directly onto the air ventilation duct in case this duct is not vibrating or oscillating due to very high air velocity or unbalanced fan.

## Step 2 - Water supply installation

### Water supply specification & quality:

Water supply pressure: 15 to 80PSI [1 to 5bar]

Water supply temperature: 37 to 105°F [3 to 40°C]

RES electric steam humidifier can accept a wide range of water quality.

Untreated water will lead to scale deposits that will need to be regularly removed from steam chamber.

Use of additives such as scale inhibitor or corrosion inhibitors, disinfectants or other can impair the normal operation of the humidifier and are not allowed.

Water supply conductivity: 1 to 1500µS/cm

Water supply hardness: 0 to 16grains/gallon [0 to 15°gH][268mg CaCO<sub>3</sub>/l]

Water supply PH: 6.5 to 7.5

Water supply chloride content: 0 to 50ppm

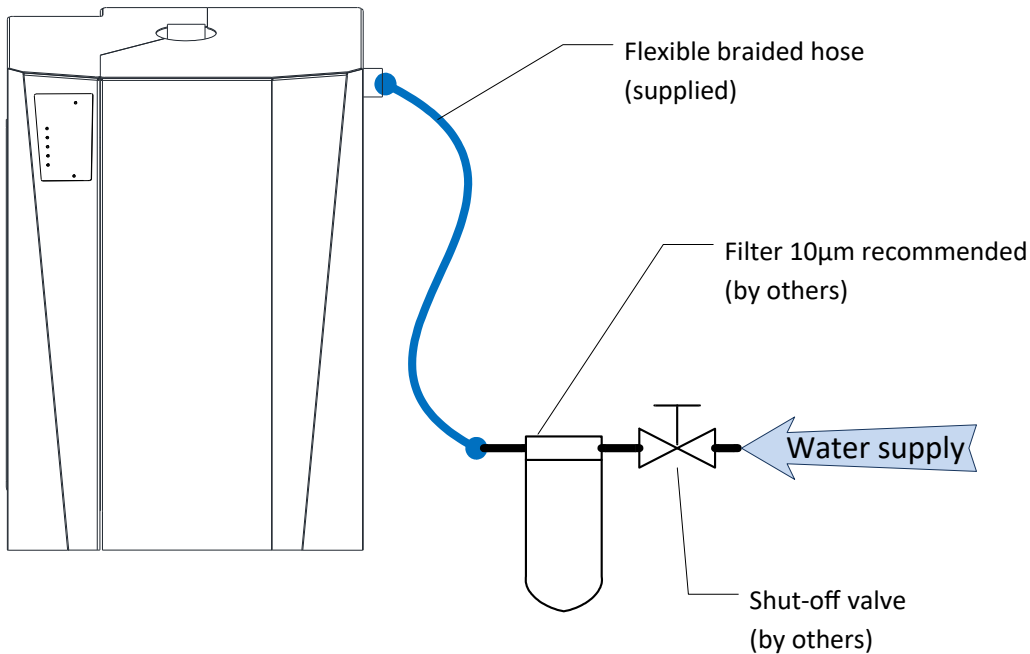

Figure 7 – water supply connection

### Water supply connection:

1. Install a manual; shut off valve on the water main line.
2. If **RES** humidifier is supplied with tap water it is recommended to install a 10µ sediment filter on the line. This filter will protect internal water fill valve from clogging.
3. A flexible braided hose is supplied for an easy and secure connection to the water supply inlet. This hose is equipped with 12mm female swivel connection at one end and G3/4 on **RES** connection side.

# Step 3 - Drain installation

## Water drained specification:

Drained water maximum temperature: 140°F [60°C] (when supplied with cold water supply)

Drained water flow rate: 2.6 GPM [10 L/min]

Drain outlet dimension: 1in [DN20]

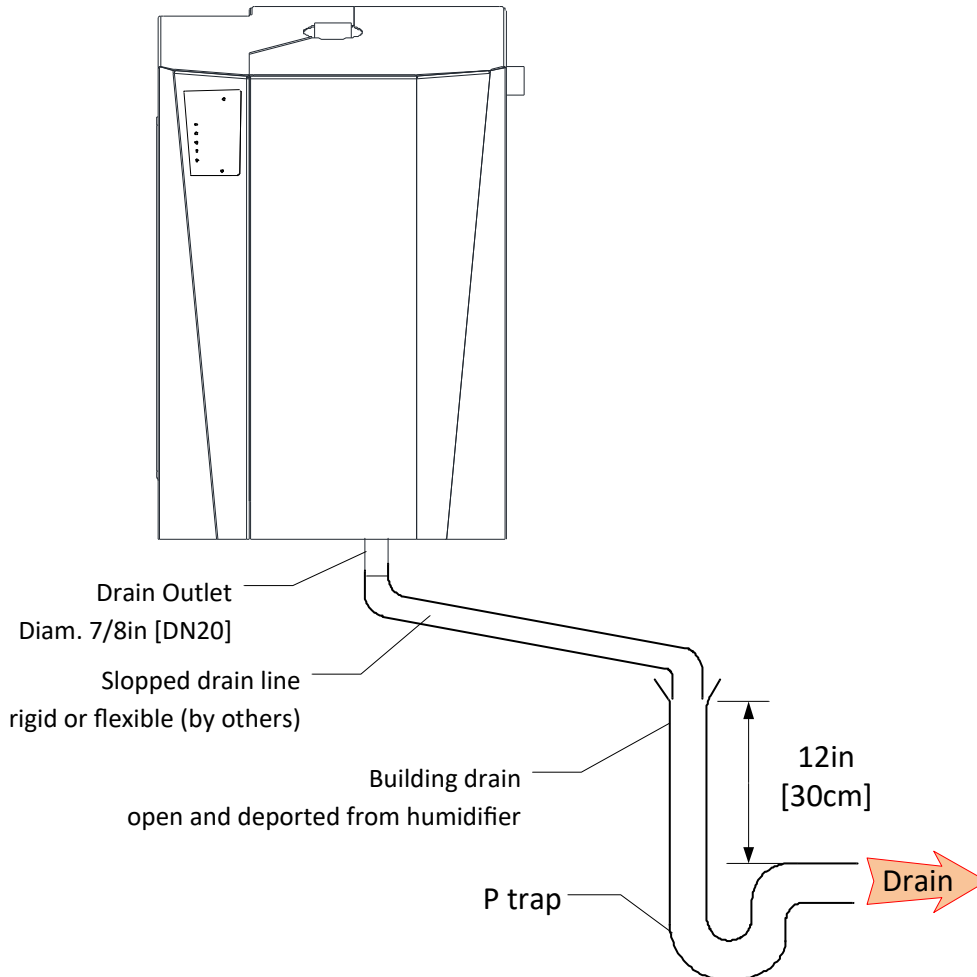

Figure 8 – water drain connection

## Installation steps :

1. Ensure that an Open drain with a P-trap is installed offset from the **RES** humidifier.
2. **IMPORTANT:** Risk of malfunction. A minimum **slope angle** of 5 degree of the drain hose or pipe and a minimum length of 8in [20cm] must be provided between the drain outlet of the **RES** humidifier and the open drain inlet.
3. A minimum of 12in [30cm] vertical run before P trap or obstruction must be provided

# Step 4 - Steam distribution

## Duct humidification

RES steam humidifier is supplied with 1m of steam hose and steam ramp.

Standard steam ramp mounting bracket is designed for installation on rectangular ventilation duct (with flat surface).

Make sure to indicate your need for steam ramp for round duct in case your ventilation is round, mounting bracket will adapt to the rounded surface of the duct.

## Horizontal duct

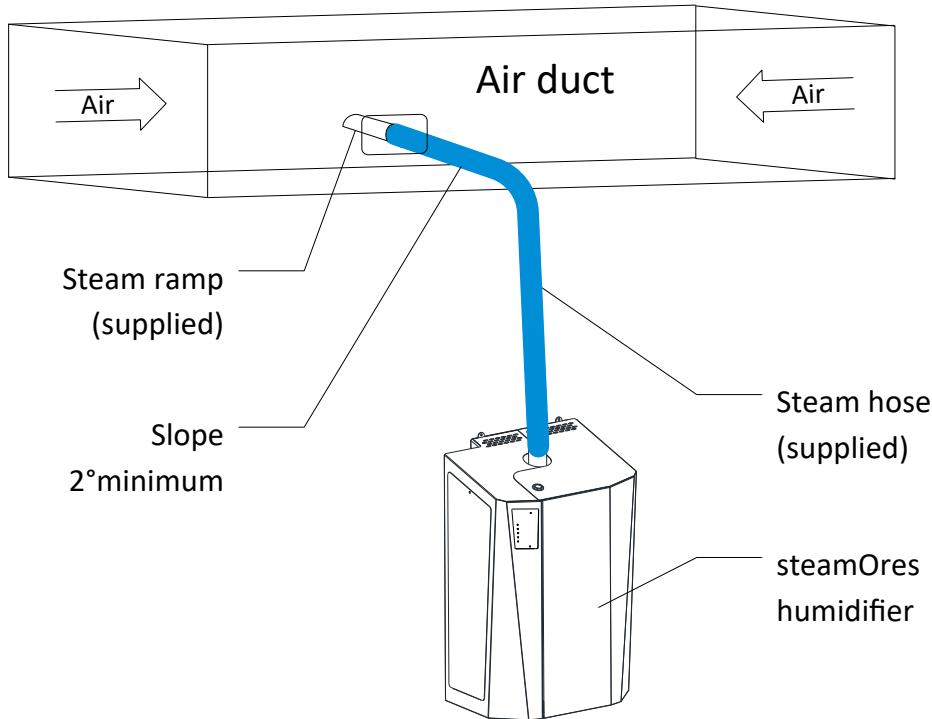

Figure 9 – Horizontal rectangular duct

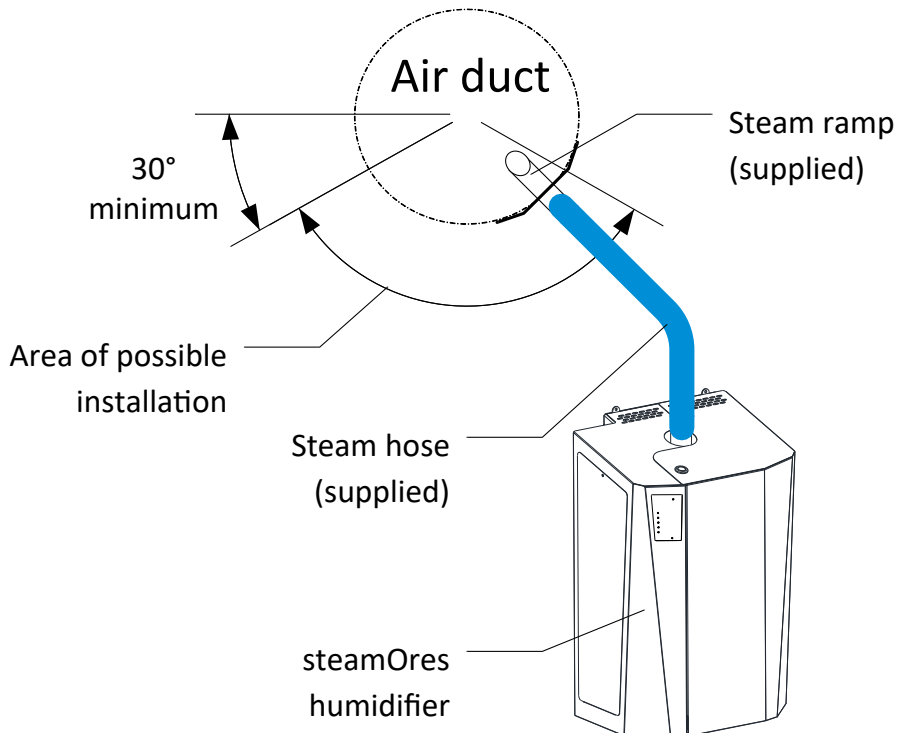

Figure 10 – Horizontal round duct

## Verical duct

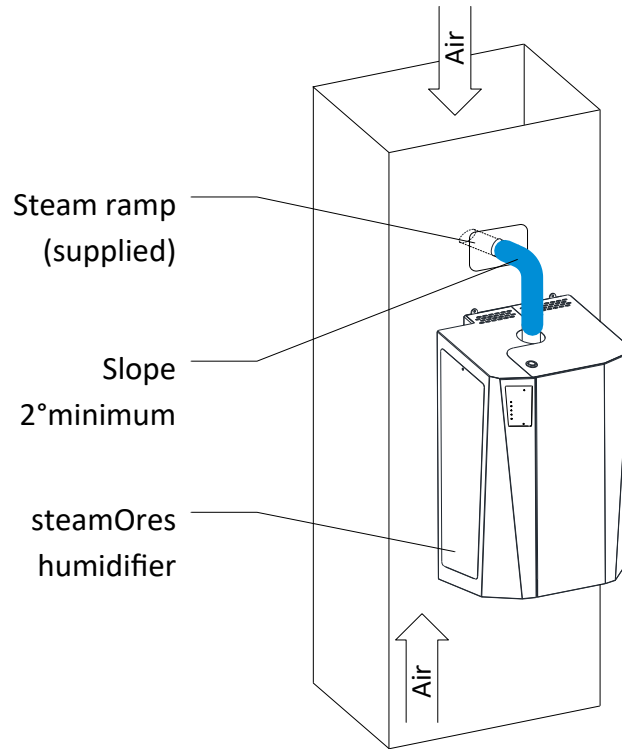

Figure 11 – vertical rectangular duct

### Installation steps :

1. Position & mount the steam ramp to the ventilation duct wall by using metal screw
2. Install steam hose in between steam ramp and RES steam humidifier.  
 Note: when using rigid steam pipe (stainless steel or copper) it is a good practice to install a small piece of steam hose to interconnect between steam ramp, rigid pipe and RES steam humidifier.  
**Important:** ensure a minimum downward slope of 2°
3. Secure all connections with hose clamps



**Caution: Risk of burnt or flooding or malfunction.**

Any obstruction in the steam hose can result in injuries and/or damage.

Ensure that there is no **kink** or **sag** in the steam hose and that this one if well maintained and attach

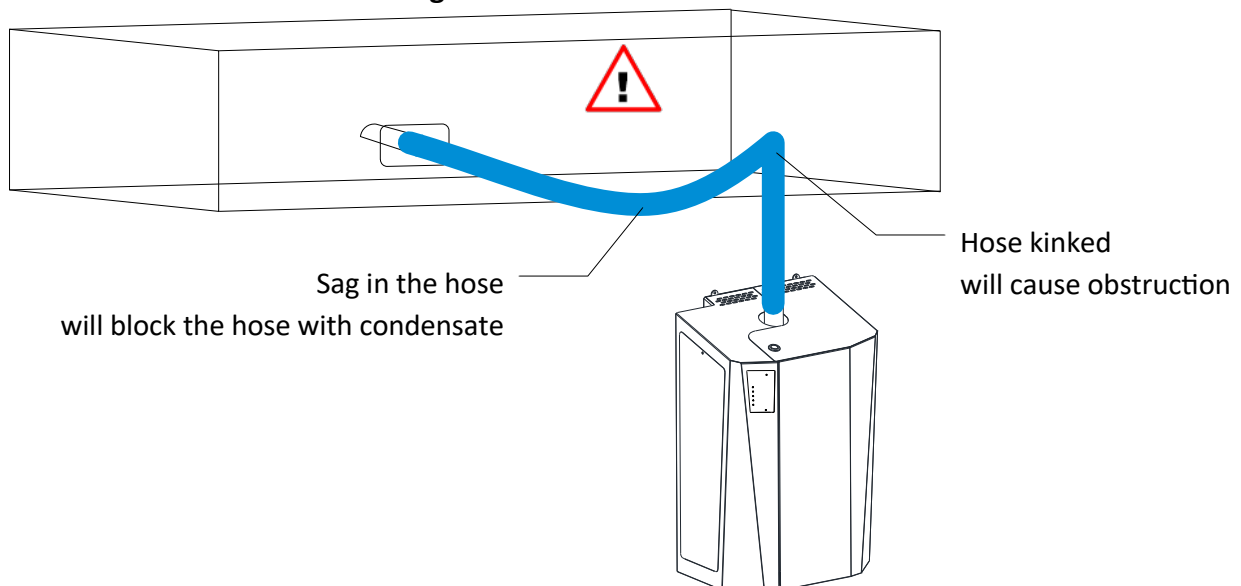

Figure 12 – Wrong steam hose installation

## In-space steam distribution – SB space blower

For in-space humidification and depending on the configuration ordered, the RES steam humidifier is supplied with the in-space distributor equipped with a fan, 6ft [2m] control cable and 3ft [1m] of steam hose if the in-space distributor is remote from the unit.

### RES-SB Built-in

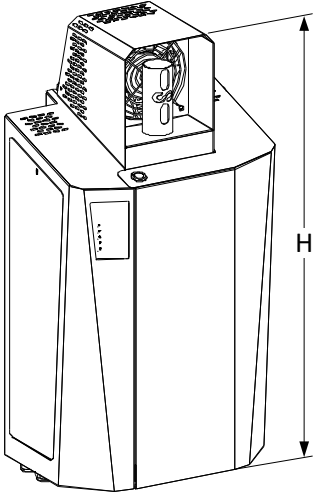

Figure 13 – RES-SB Built in

**Dimensions :**  
H=22.5in [56.3cm]

**Installation :**  
Same as standard RES

### RES-SB-RM

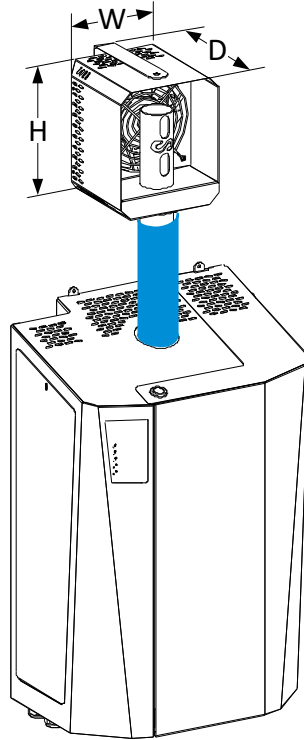

Figure 14 – RES-SB-RM remote

**Dimensions :** W=5in [12.5cm],  
H=6.5in [16.3cm],  
D=6in [15cm]

**Installation :**  
Position and secure the wall mounting bracket (supplied) using the two holes  
Ensure SB-RM distributor is levelled  
Connect steam hose  
Connect control cable to RES control board

### RES-SB-TW

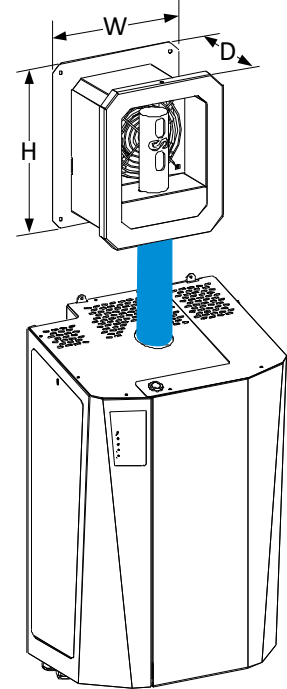

Figure 15 – RES-SB-TW through a partition wall

**Dimensions :** W=7.5in [18.8cm],  
H=9in [22.5cm],  
D=from 3.5 to 6.5in [8.8 to 16cm]

**Installation :**  
Prepare the rectangular hole in the wall using the template supplied.  
Ensure that the SB distributor is level.  
Position and attach the SB-TW body to the wall.  
Connect steam hose  
Connect the control cable to the RES control board.  
Install and screw the front and rear covers onto the SB-TW body.

## Minimum clearances for SB

There is no minimum clearance on either side of the distributor in SB space blower.

We recommend maintaining the following minimum clearances:

Right and Left side: 4 to 8in [10 to 20cm] to facilitate installation and service.

In front: 60in [1.5m] to ensure good absorption of steam to the air.

Top: 12in [30cm] for easy access and to avoid condensation on the ceiling.

# Step 5 - Power supply installation

## Electrical Warning



**Risk of electric shock.**

Any work related to power supply installation of this humidifier must comply with local code and regulation regarding safety and prevention of accidents.

## RES electrical rating

Model	Voltage	Steam Capacity	Power	Current	Power supply connection
RES120-06	120Vac/1ph	1.9lb/h (0.86kg/h)	0.6kW	5.2A	Supplied with power cord & standard plug
RES120-08		2.4lb/h (1.09kg/h)	0.8kW	6.7A	
RES120-11		3.4lb/h (1.5kg/h)	1.1kW	9.4A	
RES120-15		4.5lb/h (2.0kg/h)	1.5kW	12.5A	
RES208-19	208Vac/1ph	5.6lb/h (2.5kg/h)	1.9kW	9.1A	To be wired by Qualified electrician
RES208-24		7.2lb/h (3.3kg/h)	2.4kW	11.6A	
RES208-34		10.1lb/h (4.6kg/h)	3.4kW	16.3A	
RES208-45		13.5lb/h (6.1kg/h)	4.5kW	21.7A	
RES240-25	240Vac/1ph	7.5lb/h (3.4kg/h)	2.5kW	10.4A	
RES240-32		9.6lb/h (4.4kg/h)	3.2kW	13.3A	
RES240-45		13.5lb/h (6.1kg/h)	4.5kW	18.8A	



### General guidelines for power supply installation

Refer to the above current rated to determine the appropriate wire sizes as well as conduit size and fused disconnect requirements based on above electrical rating.

The earth must be made by solid metal to metal connections. Ground wire should be same size as power wiring.

Model	Connection
RES120-06 RES120-08 RES120-11 RES120-15	Connect <b>RES</b> steam humidifier to a standard 120Vac 1phase electrical outlet

- RES208-19
- RES208-24
- RES208-34
- RES208-45
- RES240-25
- RES240-32
- RES240-45

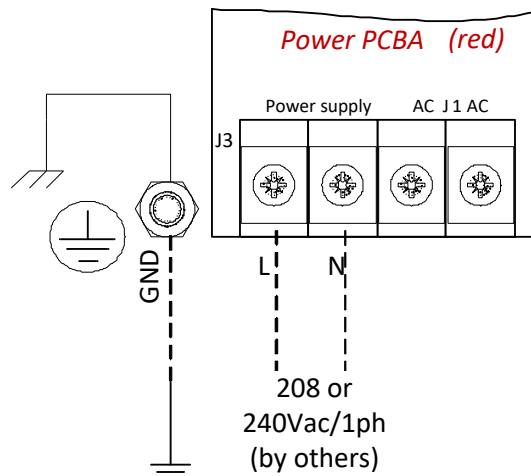

Figure 16 – Power supply connection

## Step 6 - Control installation

### General guidelines for control installation

It is a good practice to install the following safety controls:

- An air proving switch (APS) (supplied with **RES**) in the same duct as the humidifier's steam ramp so that it will prevent humidifier from producing steam in case there is no air flow.
- When the in-duct air supply temperature is below 68°F [20°C], a high limit humidistat can be installed downstream of the steam ramp so that it can prevent any over humidity or condensing in the duct (not included in the **RES** package, to be ordered separately).  
High limit humidistat is usually provided by an on-off switch its set point should be 75 to 85%RH.  
High limit humidistat should be placed at least at 10ft [3m] from the steam ramp.
- An enable dry contact can also be wired to switch the humidifier ON or OFF, this enable contact can be used either as a third safety control or as a way to control the humidifier ON and OFF, although **RES** humidifier is fully modulating.

**RES** humidifier is factory preset for external 0-10Vdc control signal.

Control source and signal can be changed at all time.

- Ensure that Air proving switch (APS) and (if applicable) Hi limit humidistat for safety are connected to the terminals HLH as represented in above wiring diagram.
- On/Off control with dry contact should be connected to terminals En-C
- External analog (modulating) signal should be connected to terminals RH/AD
- Before to connect a RH% sensor (in room or in duct) for modulating control, make sure that **RES** humidifier as been set accordingly and connect RH% sensor to terminals RH/AD as represented in below wiring diagram.

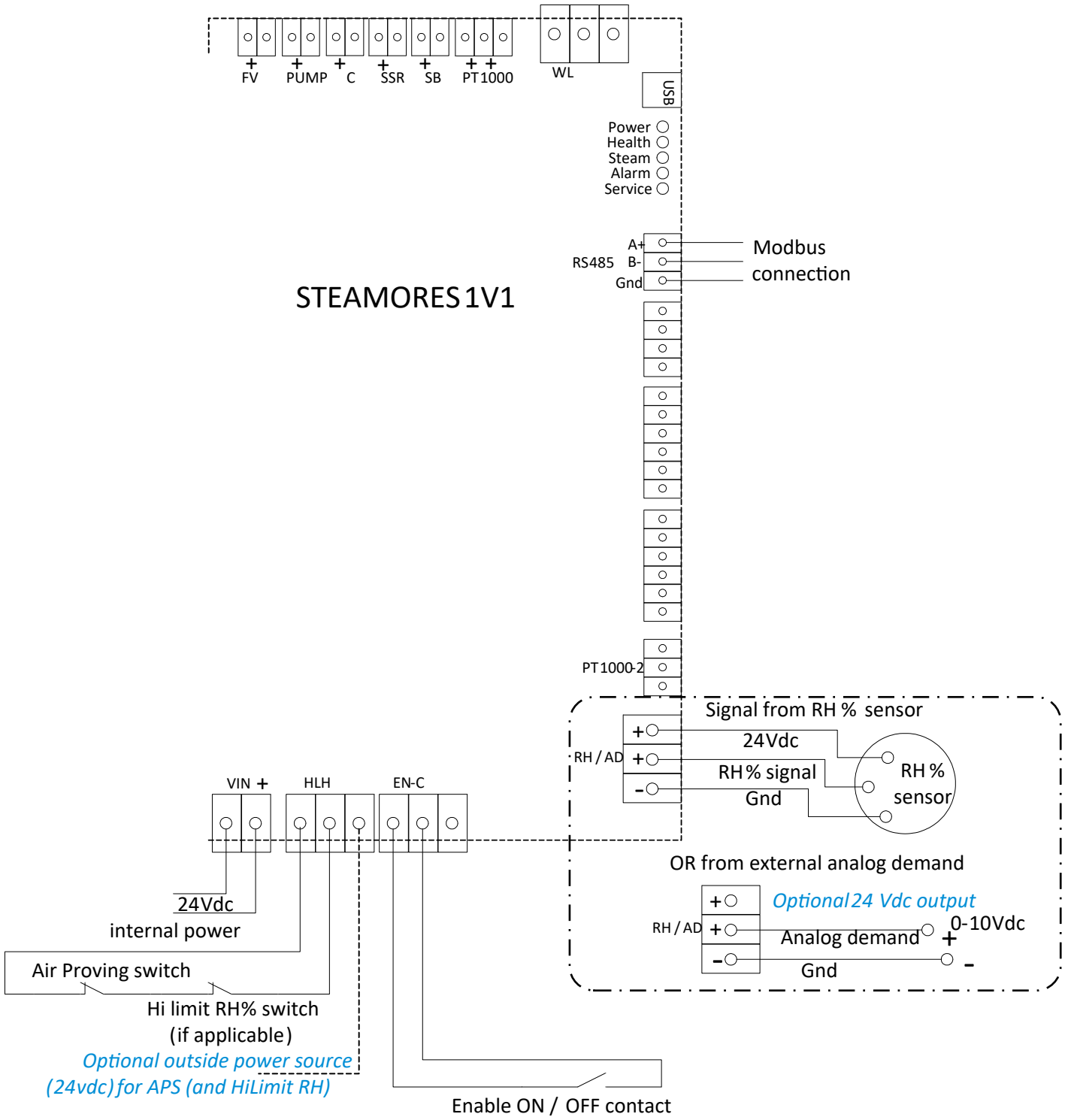

Figure 17 – Control connection

# Verification before start-up

## Warning

For safety and warranty reasons, Installation and service of this humidifier should be carried out by trained and qualified personnel.

Any work related to installation and service of this humidifier must comply with local code and regulation regarding safety and prevention of accidents.



### Risk of electric shock.

Disconnect power supply before verification.



**Risk of burnt, flooding or malfunction.** Steam lines should not have any restriction or blockage that may cause a burst of pressure in the steam line.

**Risk of flooding.** In order to avoid any risk of flooding **steamOvap** recommends an air proving switch installation in ventilation duct; and a High limit humidistat in the duct downstream the steam ramp if air supply temperature is below 68°F [20°C].

**Risk of freezing.** Plan an anti-freeze system in case of installation in a location that would be exposed to outside conditions and susceptible of freezing.

## Check list

- **Mounting**
  - Check mounting to verify that the **RES** humidifier is levelled and securely supported before filling with water.
  - In case of **RES** directly to the ventilation duct, confirm that there is no vibration or oscillation that would impair it operation.
- **Water supply**
  - Verify that all piping connections have been completed as recommended and that water pressure is available.
  - Once water shut off valve is open, verify for any possible leak.
- **Drain**
  - Verify that all drain piping has been completed as recommended and that an open drain deported from **RES** humidifier is provided.
- **Steam line**
  - Verify that all steam piping has been completed as recommended and that a slope of minimum 2° is provided.
  - Ensure that there is no sag or kink or any possible obstruction in the steam line.
- **Power supply**
  - Verify that **RES** humidifier has been connected to standard 120Vac outlet or to dedicated disconnect switch
  - Identify circuit breaker and confirm that size of circuit breaker is compatible with **RES** humidifier current rating.
- **Control circuit**
  - Verify that safety controls such as air proving switch and (when applicable) Hi limit humidistat have been connected.
  - Verify that an On/Off dry contact, or external control signal demand or RH% sensor is connected to the control terminals.

Once all above verification has been completed and found satisfactory you can powered up the **RES** humidifier.

# Configuration & Operation

## Configuration

RES steam humidifier is set and configured at our factory. It does not require any configuration on the field unless you want a non-standard configuration.

In case a non standard configuration is required, contact your local **steamOvap** representative for assistance.

Standard configuration is as follows:

Function	setting
Control source	External 0-10Vdc
Service frequency	400h
Drain frequency (to reduce mineral concentration in cylinder)	Set by dipswitches or modbus. RES120-06 & 08: 4h RES120-11: 2h30min RES120-15: 2h RES208-19, 24 & RES240-25: 1h30min RES208-34 & RES240-32: 1h RES208/240-45: 45min (above drain frequency are proportional to operation output at 100%)

## Operation

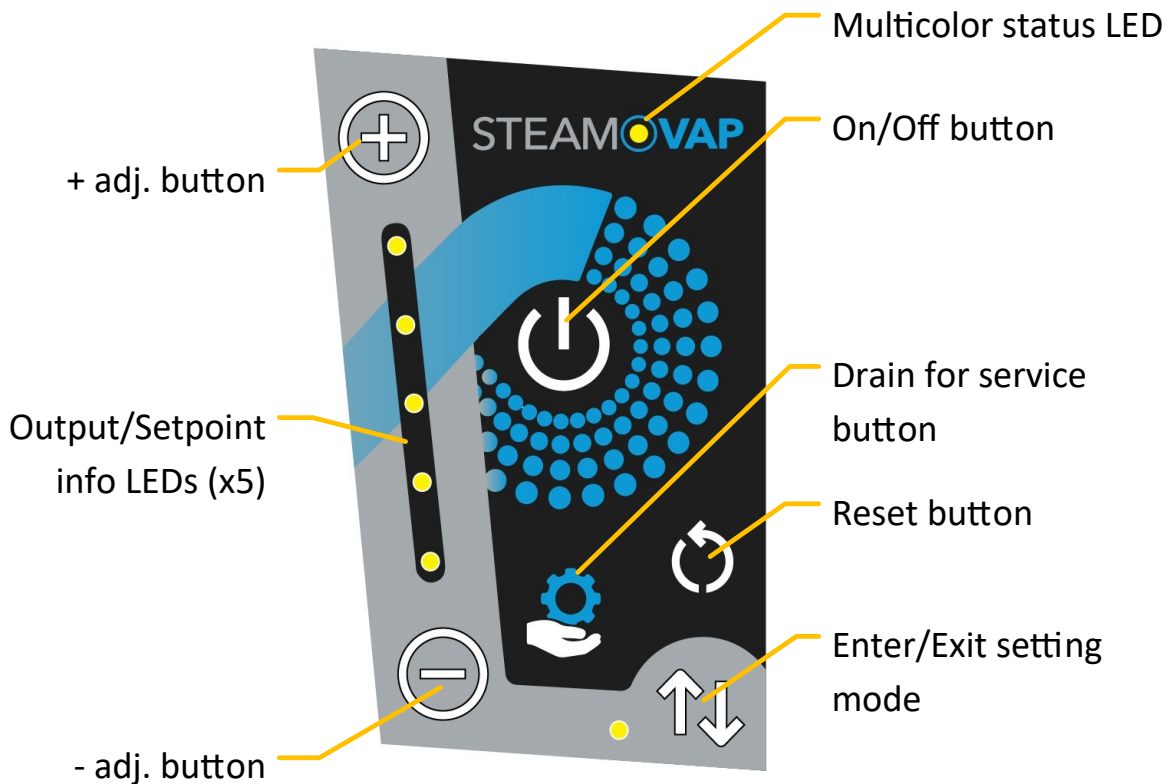

Figure 18 – RES touch pad control

## Control configuration

Touch pad control allows you to change the mode of control for the humidifier.

Press on the “setting” button on the touch pad controls, blue LED located beside this button will turn ON.

**⚠ Caution:** Risk of malfunction, change of mode should not be done without checking which control signal is connected to the RES. Incompatible mode selection and signal wiring can lead to malfunction. The mode selection is done and indicated by the five LEDs and +/- buttons located on the left hand side of the touch pad control.



To validate your selection and exit the configuration mode press simultaneously on buttons

Here below are the available modes:

Modes	External demand (0-10Vdc)	RH% sensor + Internal set-point	On/Off contact	Temperature (0-10Vdc)	Temperature (PT1000)	Modbus
5 LEDs indications	off off off off ON	off off off ON off	off off ON off off	off off off ON ON	off off ON ON off	off off ON off ON
Where to connect	Schematic #1	Schematic #2	Schematic #3	Schematic #4	Schematic #5	Schematic #6
Set point adjustment	No	Yes (20-70%RH) 5% per step 10% per LED	No	Yes 20-70°C [68-158°F] 5°C per step 10°C per LED	Yes 20-70°C [68-158°F] 5°C per step 10°C per LED	By Modbus

Schematic #1

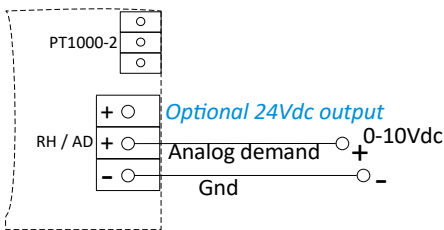

Schematic #2

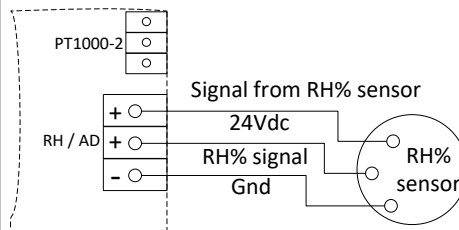

Schematic #3

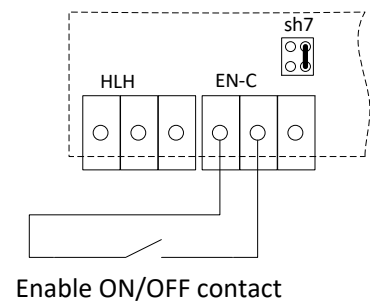

Schematic #4

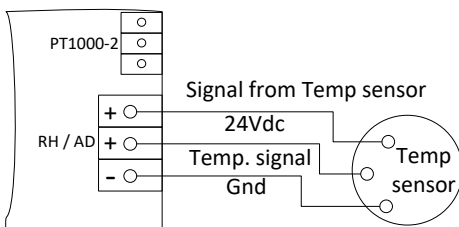

Schematic #5

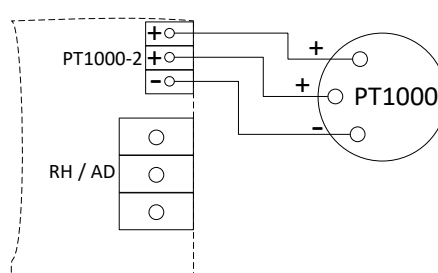

Schematic #6

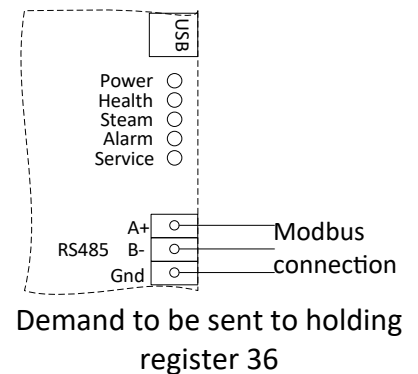

# Drain setting by dip switches

Locate the dipswitch on Main PCBA

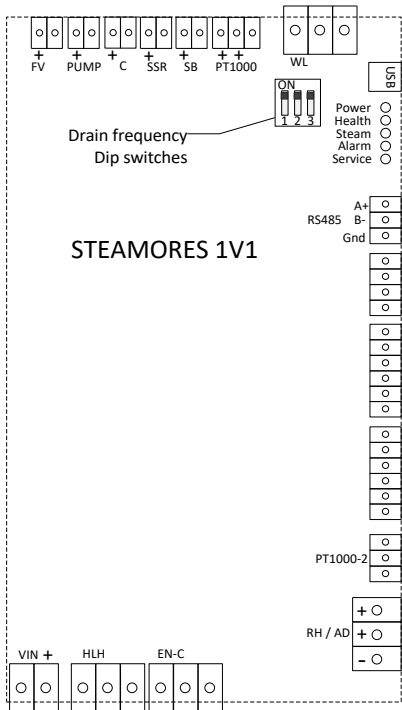

Setting 1, all DP off = Drain frequency config. by Modbus

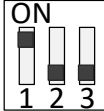

Setting 2, DP#1 On, DP#2 & 3 Off = 45min



Setting 3, DP#2 On, DP#1 & 3 Off = 1h



Setting 4, DP#1 & 2 On, DP#3 Off = 1h30min

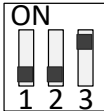

Setting 5, DP#3 On, DP#1 & 2 Off = 2h



Setting 6, DP#1 & 3 On, DP#2 Off = 2h30min

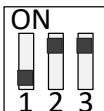

Setting 7, DP#2 & 3 On, DP#1 Off = 3h

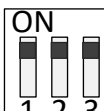

Setting 8, All DP On = 4h

Please note that the drain frequency time is proportional to the **RES** humidifier steam output. If drain frequency is 2hours and humidifier output is 50% the drain of the cylinder will occur after 4hours time.

## Multicolor status LED:

### Normal operation

LED color and state	RES state	Description
White (full ON)	Stand by	RES is disabled (On/Off button is Off)
Lime/green (full ON)	Ready	RES is ready to produce steam (waiting for signal demand)
Blue (Intensity as % demand)	Steam ON	RES is heating element.
Yellow (full ON)	Drain cycle	Drain pump is ON
Purple (full ON)	Adding water	Fill valve is ON

### Alarms

In case of alarm the multi-color LED will flash red + one of the following color

LED color and state	Alarm state	Description
Orange (Flashing with Red)	Service due	Service is due
Blue (flashing with red)	Water level	Water level sensor is defective
Dark grey (flashing with Red)	Water temp.	Water temperature sensor is defective
Purple (flashing with Red)	Water feed	Humidifier is unable to fill the cylinder
Yellow (flashing with Red)	Drain pump	Humidifier is unable to drain cylinder



In case of other alarms, multi-color LED will turn Red (Full ON)

### Other modes

LED color and state	RES state	Description
Orange (full ON)	Drain for Service	Drain for service is in progress
Deep pink (full ON)	Factory mode	RES is in Factory mode for configuration or calibration
Midnight blue (full ON)	Anti freeze	Heating element is powered, to avoid freezing
Indigo (full ON)	Pre-heat	Heating element is powered, water will not boil

## Reset

To reset all settings and return to original factory setting:

Enter the setting mode by pressing on   
 Blue LED located next to this button will be ON,  
 Then press simultaneously on buttons  &  to exit setting mode.

 **Caution:** Risk of malfunction, Make sure to re-program the correct mode according to your control configuration and wiring before to restart the humidifier (refer to Control configuration section). Incompatible mode selection and signal wiring can lead to malfunction.



# Service

**!** Risk of burnt, flooding or malfunction.  
Make sure that cylinder is empty from water before to open the release latch.

**⚡** Risk of electric shock.  
Disconnect power supply before to service.

## General guidelines for service

When service is due, RES will stop producing steam and will call for service : status LED is **orange**

1. Order a drain for service by touching the "drain for service" button,
2. Cylinder will be automatically drained and cooled by filling with fresh water at least two times, until water temperature sensor inside cylinder is measuring a temperature below 140°F [60°C].
3. When status LED is turning **white**, it is safe to open front cover and to proceed to service.
4. Confirm that the cylinder temperature is not too hot by touching it quickly with the back of your hand or fingers.
5. Confirm that cylinder has been fully drained by looking if there is water in transparent hose located at left side of cylinder.



Figure 19 – RES steam cylinder and key components

6. If temperature is Ok and that there is no water in hose, you can disconnect from power supply and open the fill & drain hose connector located below the cylinder, to do so:
  - Push on button and pull on the flexible hose on right side of the connector.
  - Once open, you can tilt the cylinder to have some more remaining water dripping in the bottom pan.
7. You can now proceed to remove the cylinder
  - Remove the safety pin securing the latch
  - Open the latch
8. You can now disengage the cylinder from the back support and remove the cylinder.
9. You can dispose of the scale flakes accumulated at the bottom of the cylinder



**Risk of damage.** Do not use chemical nor scraping with any metal tool to remove scale from cylinder, heating element of temperature sensor surface.

10. If the use of plastic brush or clean cloth is not enough to remove the scale from surface and that scale deposit is more than 15mm thick, you can use a solution of muriatic acid at 10% (1 to 10) dilution with cold water or white vinegar.  
In case of use of acidic solution or white vinegar **do not spray** such solution.  
Best results are obtained by pouring cylinder with this solution and letting it rest for few hours.
11. A full and throughout clear water rinsing is required before to re-assemble the cylinder and to put **RES** humidifier back in operation.  
Ensure that drain port and hose is not blocked by scale or debris.
12. Proceed to re-assembly with same above steps in reverse order.
  - Make sure that the cylinder is properly engaged and secured.
  - Re-install the safety pin on latch to prevent from any unintentional cylinder opening.
  - Reconnect Fill & Drain connector
13. Re-connect **RES** humidifier to power supply it will re-start automatically.

## Resetting service frequency counter

**Important:** Resetting the service frequency counter to zero is not automatic.

To reset the service frequency counter, press the “drain for service” button when the tank is empty. This may be once the tank has been drained and cooled - see step 5 above; or when the humidifier is reconnected to the power supply.

# Warranty

**steamOvap technologies inc.** (hereinafter referred to as **steamOvap**), warrant for a period of **three (3) years** after installation, that steamOvap manufactured and assembled products are free from defects in material and workmanship; except for the following products and components:

- **ACA** atomizing nozzle: **fifteen (15) year warranty**.
- **RES** humidifier water tank: **five (5) year warranty**.

**steamOvap's** obligations and liabilities under this warranty are limited to furnishing replacement parts to the customer, F.O.B. **steamovap's** factory, providing the defective part(s) is returned freight prepaid by the customer. Parts used for repairs are warranted for the balance of the term of the warranty on the original product or 90 days, whichever is longer.

No liability whatsoever shall be attached to **steamOvap** until said products have been paid for in full and then said liability shall be limited to the original purchase price for the product. Any further warranty must be in writing, signed by an officer of **steamOvap**.

**steamOvap** makes no warranty and assumes no liability unless the equipment is installed in strict accordance with installation manual in effect at the date of purchase and by qualified and trained personnel and in accordance to local codes and regulations.

**steamOvap** makes no warranty and assumes no liability whatsoever for consequential damage or damage resulting directly from misapplication, incorrect sizing or lack of proper maintenance of the equipment.

**steamOvap** retains the right to change the design, specification and performance criteria of its products without notice or obligation.

In case of litigation or dispute arising, all parties agree that the exclusive venue for any litigation shall be vested with a court of competent jurisdiction located in the Judicial District of Montreal, Quebec, Canada.



2024 © steamOvap technologies inc.  
1490 Mazurette  
Montreal, Qc, H4N 1H2  
Canada

Tel.: +1-844-357-4477  
info@steamOvap.com  
[www.steamOvap.com](http://www.steamOvap.com)

Information contained in this manual is subject to change without notice.  
To obtain the latest technical information visit our website at [www.steamOvap.com](http://www.steamOvap.com)